



TSURUMI PUMP®

BUILT FOR WORK®

SEWAGE AND
WASTEWATER PUMPS



SIMPLE DESIGN, EXTREME QUALITY | Tsurumi C Series CUTTER PUMP™

Cable Entry

Cables are designed with an anti-wicking block at motor entry where each conductor insulation is window cut and the exposed stranded wire is encapsulated in molded rubber or epoxy which eliminates moisture from wicking into the motor.



Motor

The air filled, continuous duty motors are designed to accommodate a maximum liquid temperature of 104°F. Higher temperature options may be available upon request.

Mechanical Seal

Dual mechanical seal with silicon carbide faces sits within the oil chamber. The oil prevents corrosion, abrasion or fouling of the seal's spring and seal faces due to contamination, and also provides cooling and lubrication of the seal faces, even in run-dry conditions. These are common points of failure in designs where the seal is lubricated by the pumpage as opposed to oil.



Oil Lifter

The Oil Lifter, utilizing centrifugal force, supplies lubricating oil to the upper seal faces even if oil falls below the rated volume, or pump is oriented horizontally.

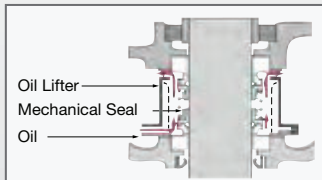

Motor Protector

A Circle Thermal Protector (CTP) integrated in the motor housing directly cuts the motor circuit if excessive heat builds up or an electrical/mechanical failure leads to overcurrent.

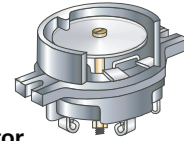

In pumps 15 HP and larger, a Miniature Thermal Protector (MTP) is embedded in each winding of the motors.



Should the winding temperature rise to the actuating temperature, the bimetal strip opens to cut off power supply.

Moisture Sensor

An internal moisture sensor is standard for all pumps 30 HP and larger. An external moisture sensor is available as an option to detect intrusion of water in the oil chamber. Internal and External sensors, when wired to a control panel, alert the operator of a potential leak.



Impeller & Cutter Plate

A tungsten carbide cutter is brazed onto the impeller vane, and rotates along the serrated entry of the cutter plate. Incoming fibrous matters are cut up which prevents clogging.



GUIDE RAIL FITTING SYSTEM

The guide rail fitting system connects the pump to and from the piping easily just by lowering and hoisting the pump, allowing easy maintenance and inspection without the need to enter the sump. Pump models used in combination with the guide rail fitting system can be identified by the prefix "TOS / TO" and "TOK". Refer to standard specifications for availability and model numbers.

The **TOS / TO** is the standard guide rail fitting system made of cast-iron and is compatible with cast-iron pumps. Pumps having a discharge bore from 2 inches to 6 inches are available for the TOS, and from 8 inches to 32 inches are available for the TO.



The **TOK** guide rail connecting system is made of a high-quality corrosion resistant resin. This system is specifically designed for use with the corrosion resistant, light weight VANCS™ pumps (Page 24).



MODEL NUMBER DESIGNATION

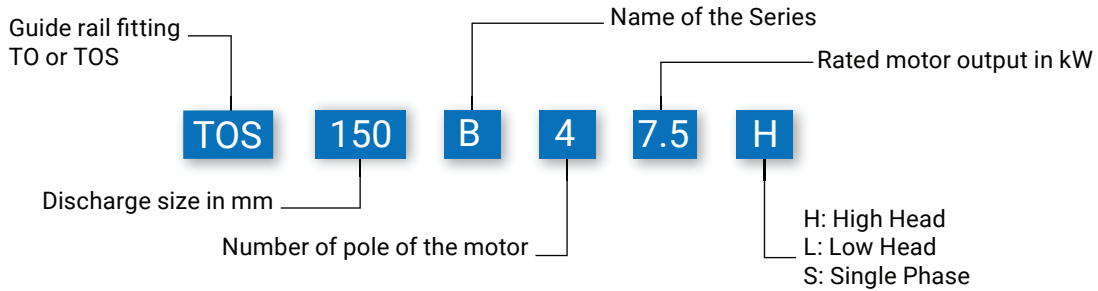

INSTALLATION

Free Standing

Simple installation in the sump saves both money and space.

Pump's with legs or a stand can sit directly on the sump floor. A discharge bend and flexible hosing allows for simple install/removal. Install the pump on a pump base if waste could clog or block its suction inlet.

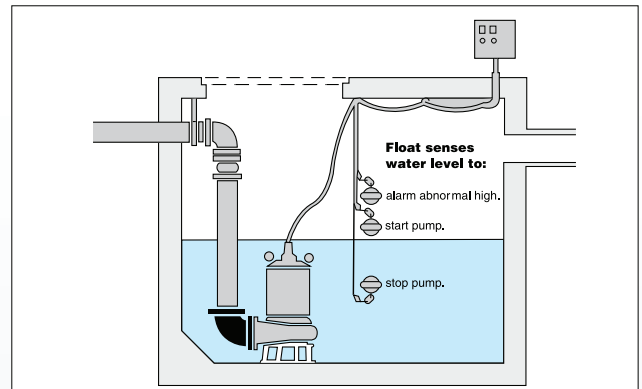

Guide-Rail Fitting

A guide rail suspends the pump with a chain for quick, easy installation or removal.

Mount the pump on the rails using a guide hook above the discharge flange. As the pump is lowered, a hook on the discharge flange locks into and positions against the discharge elbow's flange. No tools or hardware are required as the weight of the pump seals the mated flanges. To remove the pump, simply raise with the chain and the pump will lift along the guide rails.

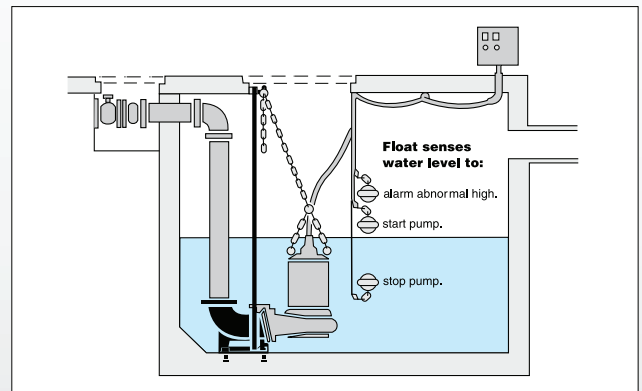

DIMENSIONAL DRAWING DESCRIPTION

Dimension: Free Standing A / B / C

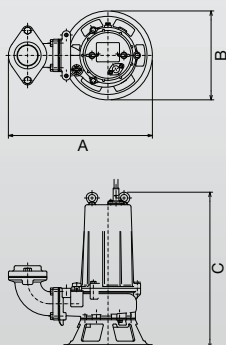

Dimension: Guide Rail Fitting (TO / TOS) D / E / F

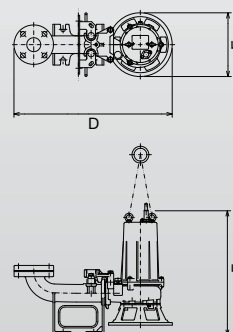

B SERIES | Sewage & Wastewater Non-Clog Submersible Pump

Our B Series non-clog pumps are used primarily in municipal water supply stations and sewage treatment plants for pumping water, sewage, and digested sludge. In industry, these pumps are efficient for controlling cooling water, process and wastewater, and abrasive materials.

Solids handling, non-clog submersible pump designed for raw sewage and wastewater in municipal, industrial and commercial applications. Offered in 2in. to 8in. with multiple impeller designs for maximum flexibility.



100B42.2



With TO /TOS Guide Rail System

Discharge Size: 2" - 3"

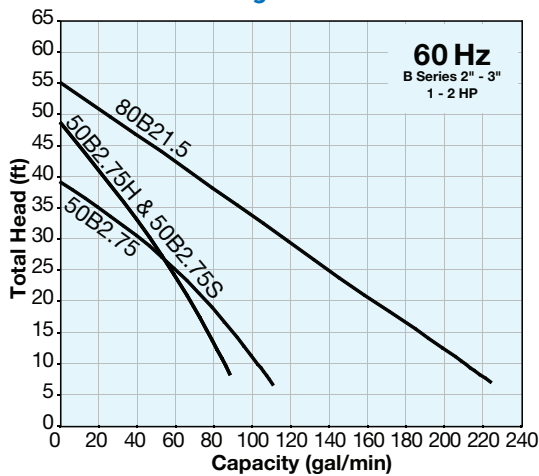

Discharge Size: 4"

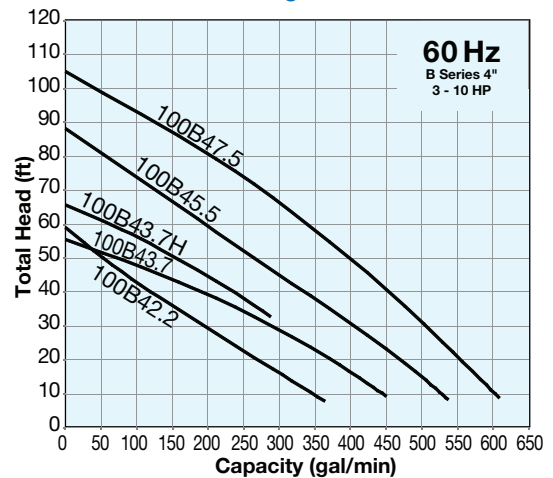

Discharge Size: 6"

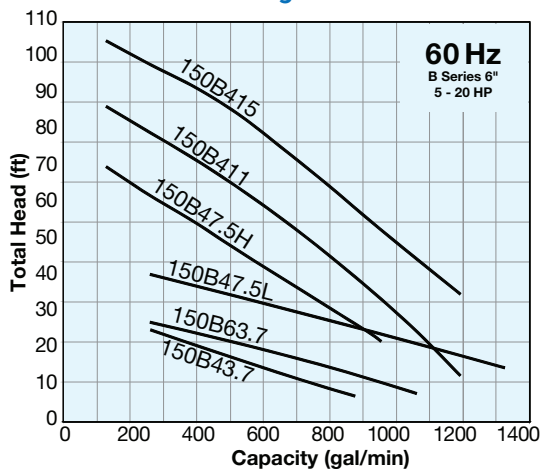

Discharge Size: 8"

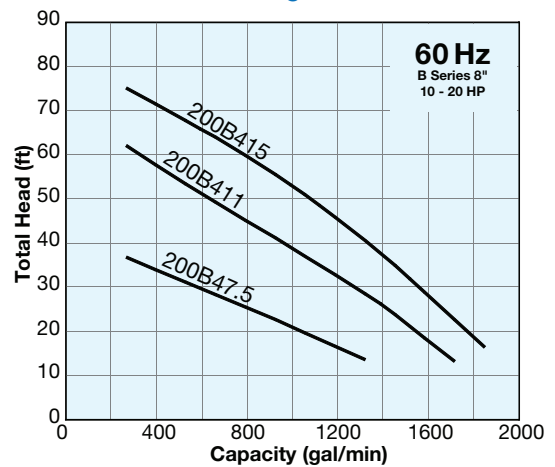

Impeller types for B series

Open Channel

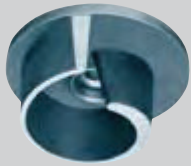

Solids Handling



Enclosed



Dimension: Free Standing A / B / C

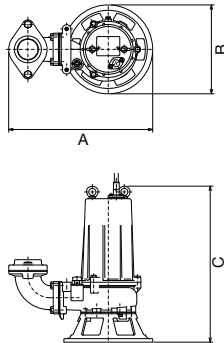

Dimension: Guide Rail Fitting (TO / TOS) D / E / F

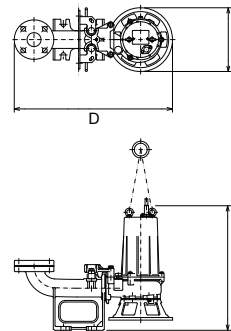

Single Phase Model	Motor Output (HP)	Rated Current (A)		*S.S. (RPM)	Discharge Size (in.)	Dimensions (in. / lbs.)						Max. Solids Dia. (in.)
		115V	230V			Free Standing Models			TOS Guide Rail Models			
						A	B	C	D	E	F	
50B2.75S	1	11.7	5.9	3600	2	15 15/16	9 13/16	20 9/16	24 7/16	9 13/16	22 5/16	0.79

Three Phase Model	Motor Output (HP)	Rated Current (A)				*S.S. (RPM)	Discharge Size (in.)	Dimensions (in. / lbs.)						Max. Solids Dia. (in.)
		208V	230V	460V	575V			Free Standing Models			TOS & TO Guide Rail Models			
								A	B	C	D	E	F	
50B2.75H	1	3.5	3.5	1.8	1.4	3600	2	15 15/16	9 13/16	16 5/16	24 7/16	9 13/16	18 1/16	0.79
50B2.75	1	3.5	3.5	1.8	1.4	3600	2	15 15/16	9 13/16	17 5/16	24 7/16	9 13/16	18 7/8	0.94
80B21.5	2	6.2	5.9	3.1	2.3	3600	3	17 9/16	9 13/16	21 1/8	26 5/8	9 13/16	23 1/16	1.38
100B42.2	3	9.4	8.5	4.3	3.5	1800	4 or 3	24 1/4	12 3/4	24 1/4	30 1/16	12 3/4	24 13/16	1.77
100B43.7H	5	15.0	13.8	6.9	5.4	1800	4 or 3	24 1/2	13 9/16	26 1/4	30 5/16	13 9/16	26 13/16	1.38
100B43.7	5	15.0	13.8	6.9	5.4	1800	4 or 3	24 7/16	13 1/8	27 3/16	30 1/4	13 1/8	27 9/16	1.77
150B43.7	5	14.7	13.8	6.9	5.4	1800	6	34 15/16	19 1/8	34 7/16	41 15/16	18 1/16	32 5/16	2.00
150B63.7	5	16.0	15.6	7.8	6.0	1200	6	33	16 11/16	35 9/16	40 5/16	15 9/16	36 7/16	2.17
100B45.5	7.5	22.6	20.5	10.3	8.1	1800	4	27 13/16	16 1/8	35 3/4	36	15 1/8	35 11/16	1.57
100B47.5	10	28.8	26.6	13.4	10.8	1800	4	27 13/16	16 1/8	36 9/16	36	15 1/8	36 1/2	1.57
150B47.5H	10	28.8	26.6	13.4	10.8	1800	6	32 13/16	16 7/16	37 1/2	40 1/2	15 7/8	38 7/16	2.76
150B47.5L	10	28.8	26.6	13.4	10.8	1800	6	34 5/16	19 1/8	42 11/16	41 15/16	18 1/16	40 9/16	1.97
200B47.5	10	28.8	26.6	13.4	10.8	1800	8	36 7/16	19 1/8	42 11/16	49 13/16	18 1/16	41 5/16	1.97
150B411	15	42.2	39.2	19.5	15.7	1800	6	35 1/4	19 5/16	43 1/4	42 7/8	18 1/4	41 7/16	2.95
200B411	15	42.2	39.2	19.5	15.7	1800	8	36 7/16	19 1/8	44 1/2	49 13/16	18 1/16	43 1/8	2.28
150B415	20	56.4	53.2	26.6	21.6	1800	6	35 1/4	19 5/16	46	42 7/8	18 1/4	44 3/16	2.95
200B415	20	56.4	53.2	26.6	21.6	1800	8	38 1/4	20 11/16	47 1/16	48 9/16	17 1/16	45 11/16	2.36

* Synchronous Speed

BK SERIES | Non-Clog Submersible Pump • Jacketed

The BK Series features an internal cooling jacket design to provide continued cooling even in the case of low sump level. This cooling jacket with the non-clog impeller design greatly reduces pump downtime. Offered in 30 HP to 50 HP three phase motor with discharge sizes ranging from 6in. to 12in.

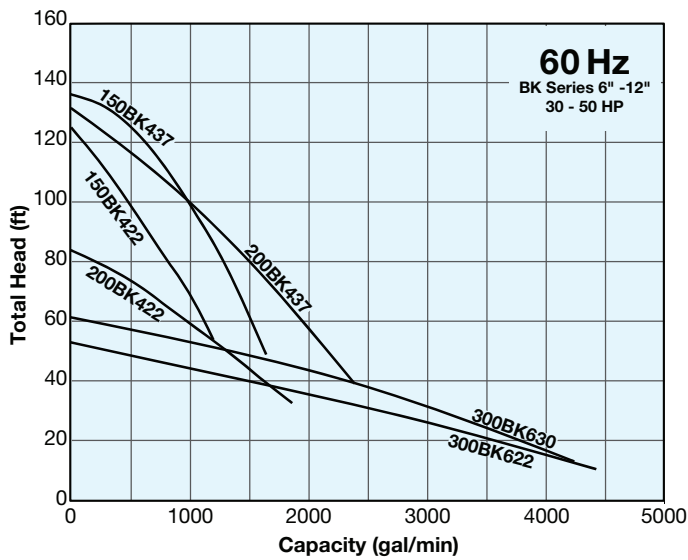

Dimension: Free Standing A / B / C

Dimension: Guide Rail Fitting (TO / TOS) D / E / F

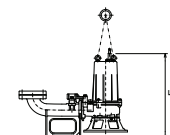
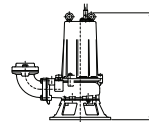
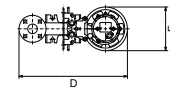
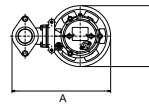

Three Phase Model	Motor Output (HP)	Rated Current (A)		*S.S. (RPM)	Discharge Size (in.)	Dimensions (in.)						Max. Solids Dia. (in.)
		460V	575V			Free Standing Models			TOS & TO Guide Rail Models			
						A	B	C	D	E	F	
150BK422	30	39	31.5	1800	6	38 7/8	21 1/4	52 1/8	46 1/4	20 1/2	51 5/16	2.95
200BK422	30	39	31.5	1800	8	42 13/16	24 7/16	50 3/4	53 3/8	21 5/8	51 15/16	2.95
300BK622	30	41	33	1200	12	53 3/4	29 15/16	63 9/16	66 5/16	27 3/8	63 11/16	3.27
300BK630	40	56	45	1200	12	53 3/4	29 15/16	67 3/16	66 5/16	27 3/8	67 5/16	2.76
150BK437	50	64	50	1800	6	42 11/16	28 1/2	63 11/16	51 7/16	24 7/16	57 1/16	1.57
200BK437	50	64	50	1800	8	46 7/8	28 1/2	64 9/16	56 3/16	24 3/8	60 1/8	1.57

* Synchronous Speed

BZ SERIES | Non-Clog Submersible Pump • Jacketed & Non-Jacketed

Highly reliable and durable, Tsurumi BZ Series pumps are designed and built for sound quality and continuous duty that can help you keep your systems - whether for wastewater drainage, pumping or flood control - running stably and greatly reduce your maintenance costs. As an option, the pumps can be adapted for seawater, high temperature liquids or other special application, paving the way for their use at shipyards and power plants for water intake and discharge.



100BZ47.5



250BZ455



200BZ622

Shrouded Channel Impeller with Wide Passages to Prevent Clogging

– Over 3 Inches Passage –

BZ Series pumps come with wide passages of over 3 inches in diameter to minimize trouble due to clogged solids and fibrous matter. They adopt a shrouded single/two-channel impeller.



Shrouded Channel Impeller

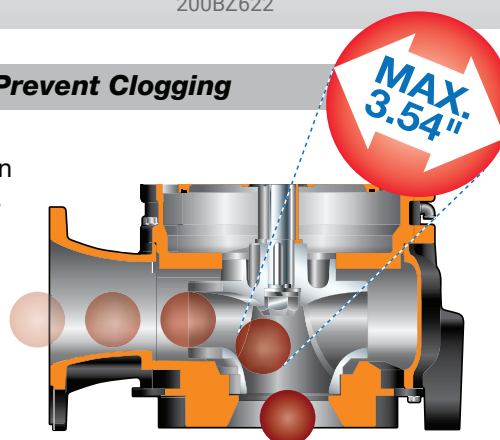

BZ SERIES | Non-Clog Submersible Pump • Jacketed & Non-Jacketed

Group Curves

BZ Series: Jacketed

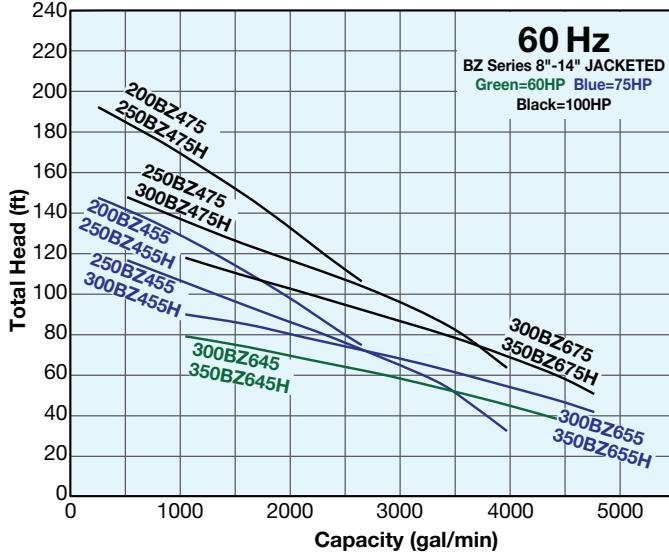

BZ Series: Non-Jacketed

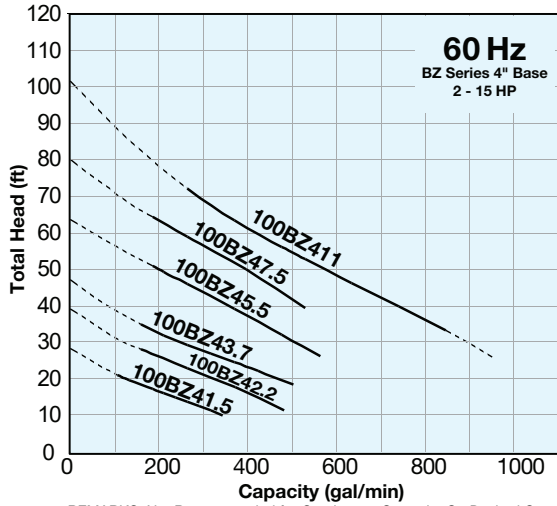

REMARKS: Not Recommended for Continuous Operation On Dashed Curve.

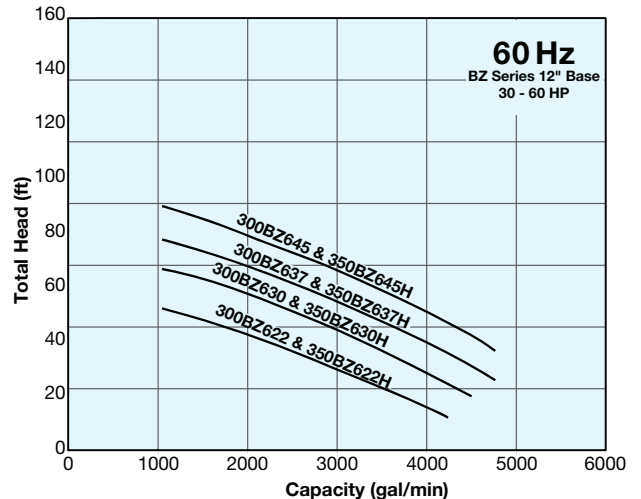
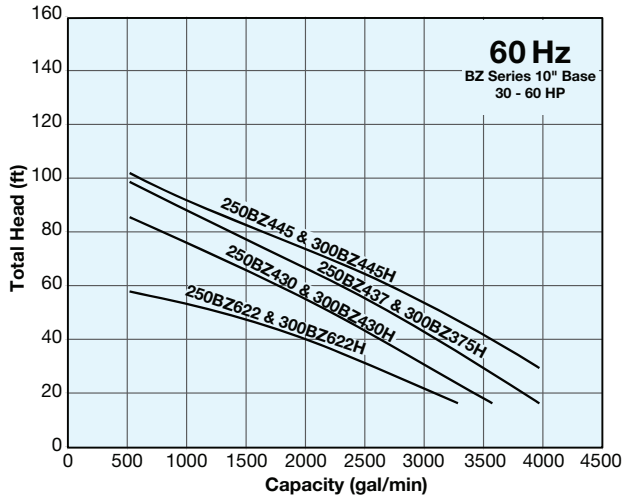
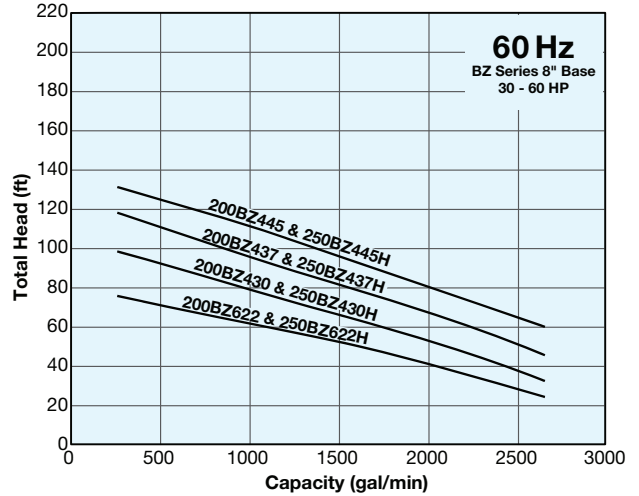

BZ SERIES | Non-Clog Submersible Pump • Jacketed & Non-Jacketed

Specifications

BZ Series: Jacketed

Three Phase Model	Motor Output (HP)	Rated Current (A)				*S.S. (RPM)	Discharge Size (in.)	Dimensions (in.)						Max. Solids Dia. (in.)
		208V	230V	460V	575V			Free Standing Models			TOS Guide Rail Models			
								A	B	C	D	E	F	
200BZ455	75	N/A	N/A	CF	CF	1800	8	47 9/16	29 15/16	68 3/8	57 1/2	26	64 13/16	3.00
250BZ455H	75	N/A	N/A	CF	CF	1800	10	51 11/16	29 15/16	68 3/8	62 1/16	26	63 3/4	3.00
200BZ475	100	N/A	N/A	CF	CF	1800	8	47 9/16	29 15/16	68 3/8	56 9/16	26	64 13/16	3.00
250BZ475H	100	N/A	N/A	CF	CF	1800	10	51 11/16	29 15/16	68 3/8	62 1/16	26	63 3/4	3.00
250BZ455	75	N/A	N/A	CF	CF	1800	10	48 5/8	28 1/2	70 15/16	58 1/2	25 1/16	65 9/16	3.15
300BZ455H	75	N/A	N/A	CF	CF	1800	12	50 11/16	28 1/2	70 15/16	62 3/16	25 1/16	66 1/2	3.15
250BZ475	100	N/A	N/A	CF	CF	1800	10	48 5/8	28 1/2	70 15/16	58 1/2	25 1/16	65 9/16	3.15
300BZ475H	100	N/A	N/A	CF	CF	1800	12	50 11/16	28 1/2	70 15/16	62 3/16	25 1/16	66 1/2	3.15
300BZ645	60	N/A	N/A	CF	CF	1200	12	54 9/16	31 1/2	72 5/8	65 7/8	26 3/4	67 5/8	3.54
350BZ645H	60	N/A	N/A	CF	CF	1200	14	59 3/8	31 1/2	72 5/8	68 7/8	26 3/4	69 7/16	3.54
300BZ655	75	N/A	N/A	CF	CF	1200	12	54 9/16	31 1/2	72 5/8	65 7/8	26 3/4	67 5/8	3.54
350BZ655H	75	N/A	N/A	CF	CF	1200	14	59 3/8	31 1/2	72 5/8	68 7/8	26 3/4	69 7/16	3.54
300BZ475	100	N/A	N/A	CF	CF	1800	12	54 9/16	31 1/2	72	65 7/8	26 3/4	67	3.54
350BZ475H	100	N/A	N/A	CF	CF	1800	14	59 3/8	31 1/2	72	68 7/8	26 3/4	68 3/4	3.54

* Synchronous Speed

BZ Series: Non-Jacketed

Three Phase Model	Motor Output (HP)	Rated Current (A)				*S.S. (RPM)	Discharge Size (in.)	Dimensions (in.)						Max. Solids Dia. (in.)
		208V	230V	460V	575V			Free Standing Models			TOS Guide Rail Models			
								A	B	C	D	E	F	
100BZ41.5	2	8.0	8.0	4.0	3.0	1800	4	22 1/2	10 3/4	24 13/16	28 5/16	10 3/4	25 7/16	3.15
100BZ42.2	3	9.8	9.2	4.6	3.6	1800	4	22 1/2	10 3/4	24 13/16	28 5/16	10 3/4	25 7/16	3.15
100BZ43.7	5	15.0	14.2	7.3	5.4	1800	4	23 13/16	11 3/8	26 13/16	29 5/8	11 3/8	27 3/8	3.15
100BZ45.5	7.5	22.2	20.8	10.4	8.3	1800	4	29	16 9/16	36 7/16	37 3/16	16	36	3.15
100BZ47.5	10	29.8	28.0	14.0	11.5	1800	4	29	16 9/16	37 3/16	37 3/16	16	36 13/16	3.15
100BZ411	15	41.4	38.0	19.0	14.7	1800	4	29 7/16	16 15/16	40 1/4	37 5/8	16 7/8	40	3.15
200BZ622	30	N/A	N/A	CF	CF	1200	8	47 9/16	29 15/16	62 3/8	57 7/16	26	58 13/16	3.00
250BZ622H	30	N/A	N/A	CF	CF	1200	10	51 11/16	29 15/16	62 3/8	62 1/16	26	57 3/4	3.00
200BZ430	40	N/A	N/A	CF	CF	1800	8	47 9/16	29 15/16	59 3/16	57 7/16	26	55 1/2	3.00
250BZ430H	40	N/A	N/A	CF	CF	1800	10	51 11/16	29 15/16	59 3/16	62 1/8	26	54 1/2	3.00
200BZ437	50	N/A	N/A	CF	CF	1800	8	47 9/16	29 15/16	61 7/8	57 7/16	26	58 3/8	3.00
250BZ437H	50	N/A	N/A	CF	CF	1800	10	51 11/16	29 15/16	61 7/8	62 1/16	26	57 5/16	3.00
200BZ445	60	N/A	N/A	CF	CF	1800	8	47 9/16	29 15/16	62 3/8	57 7/16	26	58 13/16	3.00
250BZ445H	60	N/A	N/A	CF	CF	1800	10	51 11/16	29 15/16	62 3/8	62 1/16	26	57 3/4	3.00
250BZ622	30	N/A	N/A	CF	CF	1200	10	48 5/8	28 1/2	64 15/16	58 1/2	24 1/4	59 5/8	3.15
300BZ622H	30	N/A	N/A	CF	CF	1200	12	50 11/16	28 1/2	64 15/16	62 3/16	24 1/4	60 1/2	3.15
250BZ430	40	N/A	N/A	CF	CF	1800	10	48 5/8	28 1/2	61 13/16	58 1/2	24 1/4	56 7/16	3.11
300BZ430H	40	N/A	N/A	CF	CF	1800	12	50 11/16	28 1/2	61 13/16	62 3/16	24 1/4	57 3/8	3.11
250BZ437	50	N/A	N/A	CF	CF	1800	10	48 5/8	28 1/2	64 1/2	58 1/2	24 1/4	59 9/16	3.11
300BZ437H	50	N/A	N/A	CF	CF	1800	12	50 11/16	28 1/2	64 1/2	62 3/16	24 1/4	60 1/16	3.11
250BZ445	60	N/A	N/A	CF	CF	1800	10	48 5/8	28 1/2	64 15/16	58 1/2	24 1/4	59 5/8	3.11
300BZ445H	60	N/A	N/A	CF	CF	1800	12	50 11/16	28 1/2	64 15/16	62 3/16	24 1/4	60 1/2	3.11
300BZ622	30	N/A	N/A	CF	CF	1200	12	54 9/16	31 1/2	66	65 7/8	25 7/8	61	3.54
350BZ622H	30	N/A	N/A	CF	CF	1200	14	59 3/8	31 1/2	66	68 7/8	25 7/8	62 13/16	3.54
300BZ630	40	N/A	N/A	CF	CF	1200	12	54 9/16	31 1/2	66	65 7/8	25 7/8	61	3.54
350BZ630H	40	N/A	N/A	CF	CF	1200	14	59 3/8	31 1/2	66	68 7/8	25 7/8	62 13/16	3.54
300BZ637	50	N/A	N/A	CF	CF	1200	12	54 9/16	31 1/2	66	65 7/8	25 7/8	61	3.54
350BZ637H	50	N/A	N/A	CF	CF	1200	14	59 3/8	31 1/2	66	68 7/8	25 7/8	62 13/16	3.54

* Synchronous Speed

Dimension: Free Standing A / B / C

Dimension: Guide Rail Fitting (TO / TOS) D / E / F

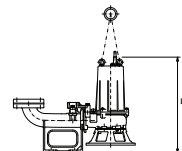
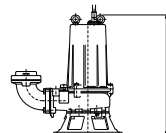
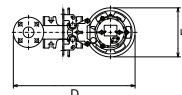
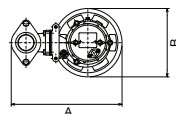

C SERIES | Tsurumi C Series CUTTER PUMP™

Tsurumi C Series Cutter Pump™ is a solids handling non-clog submersible pump with a unique tungsten carbide tipped single or multi-vane impeller and high chrome serrated wear plate for shredding of solids. Designed for municipal, industrial and commercial applications; the C-Series is offered in 1 HP to 30 HP single and three phase motors.

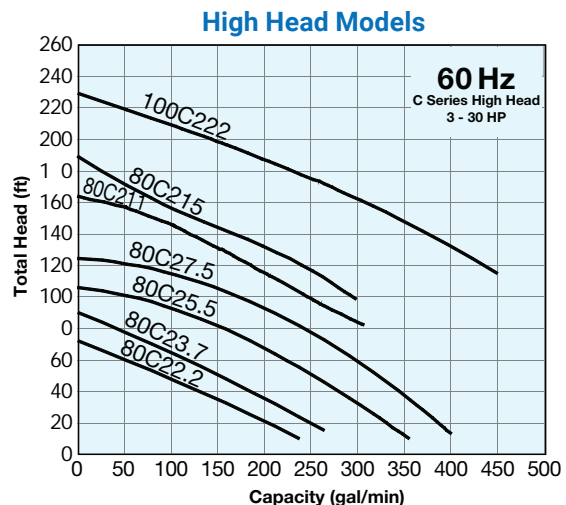
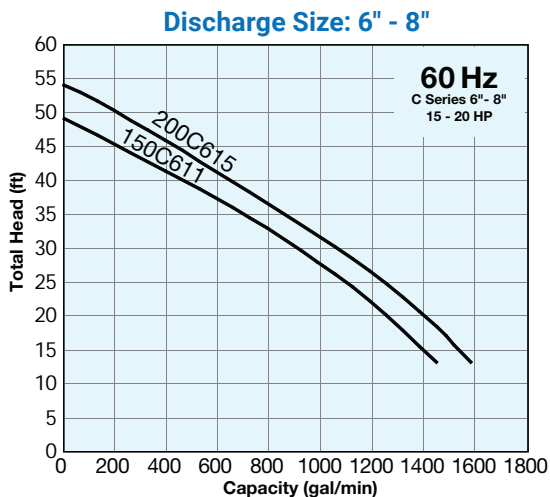
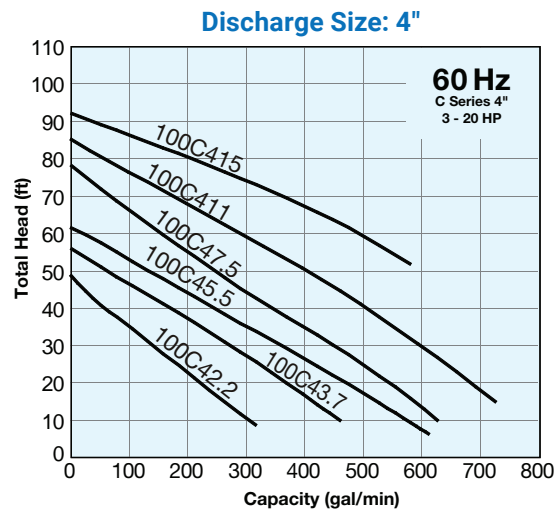
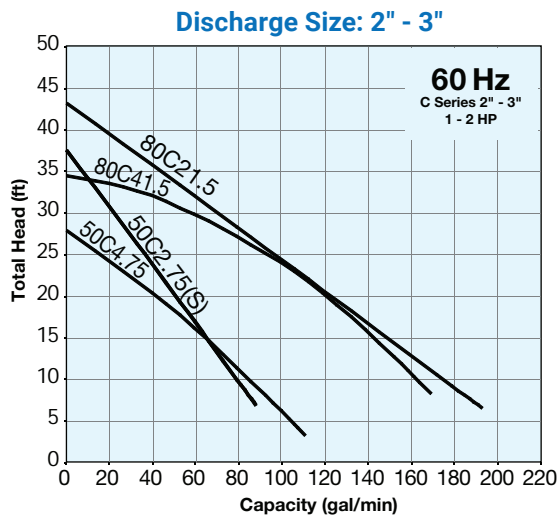

Applications

- Municipal wet well lift stations
- Municipal dry pit stations
- Retail stores / restaurants
- Sewer bypass
- Nursing homes / housing developments
- Prisons
- Hospitals
- Pulp and paper mills
- Industrial processing
- Oil refining
- Food processing
- Farming
- Campgrounds
- Hotels

Optional Discharge with 3" & 4" Discharge Size

Reduced overall width allows pump to be used in confined areas, including sewer bypass applications. Please contact factory for specific dimensions.
(Also compatible with other models)



Dimension: Free Standing A / B / C

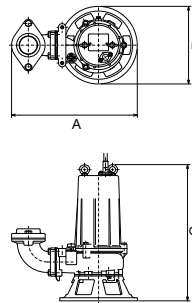

Dimension: Guide Rail Fitting (TO / TOS) D / E / F

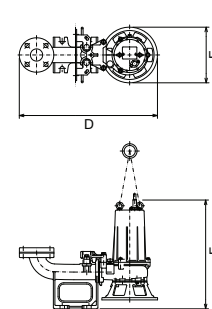

Single Phase Model	Motor Output (HP)	Rated Current (A)				*S.S. (RPM)	Discharge Size (in.)	Dimensions (in.)						Max. Solids Dia. (in.)
		115V		230V				Free Standing Models			TOS Guide Rail Models			
		A	B	C	D			E	F					
50C2.75S*	1	11.7	5.9			3600	2	15 15/16	9 13/16	20 9/16	24 7/16	9 13/16	22 5/16	0.83

Three Phase Model	Motor Output (HP)	Rated Current (A)				*S.S. (RPM)	Discharge Size (in.)	Dimensions (in.)						Max. Solids Dia. (in.)
		208V	230V	460V	575V			Free Standing Models			TOS Guide Rail Models			
		A	B	C	D			E	F					
50C2.75*	1	3.5	3.5	1.8	1.4	3600	2	15 15/16	9 13/16	16 5/16	24 7/16	9 13/16	18 1/16	0.83
50C4.75	1	3.5	3.6	1.8	1.5	1800	2	16 13/16	11 3/16	19 5/8	25 5/16	11 3/16	21 9/16	1.02
80C21.5*	2	6.2	5.9	3.1	2.3	3600	3	17 9/16	9 13/16	21 1/8	26 5/8	9 13/16	23 1/16	1.18
80C41.5	2	6.6	6.4	3.2	2.6	1800	3	19 5/8	12 7/16	22 5/8	28 11/16	12 7/16	23 7/8	1.26
100C42.2	3	9.4	8.5	4.3	3.5	1800	3 or 4	24 3/16	12 3/4	24 1/4	30 1/16	12 3/4	24 13/16	1.73
100C43.7	5	15.0	13.8	6.9	5.4	1800	3 or 4	24 3/8	13 1/8	27 3/16	30 1/4	13 1/8	27 9/16	2.17
100C45.5	7.5	22.2	20.8	10.4	8.1	1800	4	27 13/16	16 1/8	35 3/4	36	15 1/8	35 11/16	1.57
100C47.5	10	29.8	28.0	14.0	10.8	1800	4	27 13/16	16 1/8	36 9/16	36	15 1/8	36 1/2	1.57
100C411	15	41.4	38.0	19.0	14.7	1800	4	28 11/16	17 3/16	39 3/8	37 1/8	16 15/16	39 5/16	1.97
100C415	20	55.8	51.6	25.8	20.6	1800	4	28 5/8	17 3/16	42 1/2	36 13/16	16 11/16	42 7/16	1.57
150C611	15	43.0	39.0	19.5	15.5	1200	6	41 1/16	23 11/16	47 11/16	48 3/8	22	46 5/16	3.62
200C615	20	58.0	52.0	26.0	21.0	1200	8	43 1/4	23 11/16	49 5/8	56 1/4	22	49 1/16	3.62

* Not for use in commercial applications (Residential sewage only)

Three Phase Model: High Head	Motor Output (HP)	Rated Current (A)				*S.S. (RPM)	Discharge Size (in.)	Dimensions (in.)						Max. Solids Dia. (in.)
		208V	230V	460V	575V			Free Standing Models			TOS Guide Rail Models			
		A	B	C	D			E	F					
80C22.2	3	10.0	9.8	4.9	3.8	3600	3	21 1/8	10 1/4	24 1/16	27 5/16	10 1/4	25 3/16	0.79
80C23.7	5	14.4	13.6	6.8	5.3	3600	3	21 1/8	10 1/4	24 1/16	27 5/16	10 1/4	25 3/16	0.87
80C25.5	7.5	22.3	21.4	10.7	8.3	3600	3	24 15/16	13 9/16	34 5/8	31 1/16	12 5/8	35 1/2	0.91
80C27.5	10	26.9	25.6	13.0	10.2	3600	3	24 15/16	13 9/16	34 5/8	31 1/16	12 5/8	35 1/2	0.91
80C211	15	40.8	39.2	19.6	15.4	3600	3	24 15/16	13 9/16	36 1/2	31 1/16	12 5/8	36 7/16	0.98
80C215	20	54.0	50.0	25.0	20.0	3600	3	28 3/4	16 15/16	42 3/4	36 13/16	16 15/16	42 3/4	1.02
100C222	30	---	---	35.0	28.0	3600	4	33 3/4	20 1/16	46 5/8	40 3/8	20 1/16	46 5/8	1.02

* S.S. = Synchronous Speed

U SERIES | Semi-Vortex Cast Iron Impeller

Tsurumi's U Series pumps provide exceptional capabilities for those small to mid-range applications in which solids and stringy materials can be problematic.

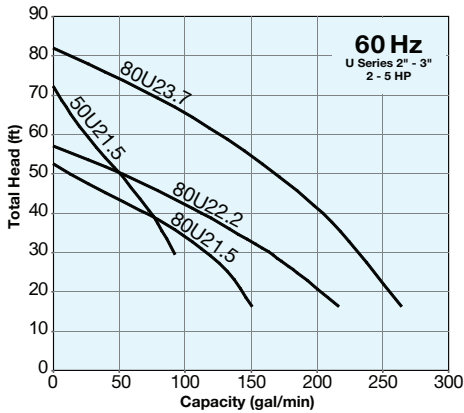

U Series pump with elbow

Dimension: Free Standing A / B / C Dimension: Guide Rail Fitting (TO / TOS) D / E / F

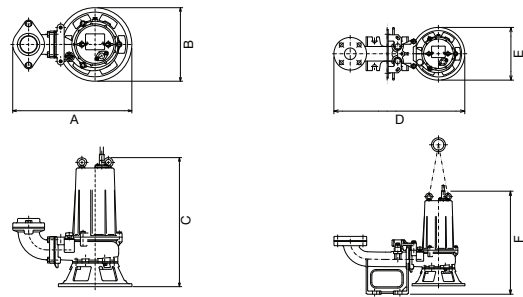

Three Phase Model	Motor Output (HP)	Rated Current (A)				*S.S. (RPM)	Discharge Size (in.)	Dimensions (in.)						Max. Solids Dia. (in.)
		208V	230V	460V	575V			Free Standing Models			TOS Guide Rail Models			
								A	B	C	D	E	F	
50U21.5	2	6.2	5.9	3.1	2.3	3600	2	11 11/16	7 15/16	18 3/8	25 7/8	7 15/16	18 13/16	1.38
80U21.5	2	6.2	5.9	3.1	2.3	3600	3	16 9/16	7 15/16	19 5/8	23 7/8	7 15/16	23 11/16	1.81
80U22.2	3	9.4	8.8	4.4	3.5	3600	3	20 1/2	9 7/16	22 1/8	24 15/16	9 7/16	25 1/2	2.20
80U23.7	5	14.4	13.6	6.8	5.3	3600	3	20 1/2	9 3/16	22 1/4	24 15/16	9 3/16	25 9/16	2.20

* Synchronous Speed

UT • UTZ SERIES | Single Phase Cast Iron Submersible Sewage Pump

The UT Series pumps are compact economical cast iron pumps. It features a large passage ideal for applications with solids laden liquids. Available with float switches for automatic operation (50UTZ2.4S and 50UTZ2.75S).

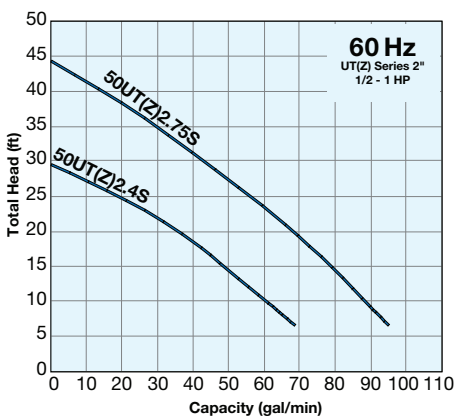

50UT2.4S



50UTZ2.4S

Dimension: 50UT2.4S/2.75S

Dimension: 50UTZ2.4S/2.75S

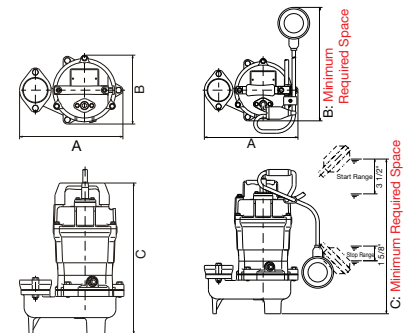

Single Phase Model	Motor Output (HP)	Rated Current (A)		*S.S. (RPM)	Discharge Size (in.)	Dimensions (in.)			Max. Solids Dia. (in.)
		115V	230V			Free Standing Models			
						A	B	C	
50UT2.4S	1/2	5.7	—	3600	2	9 1/2	6 3/8	13 3/4	1.40
50UTZ2.4S	1/2	5.7	—	3600	2	9 1/2	11 5/8 ^{*1}	15 3/4 ^{*1}	1.40
50UT2.75S	1	9.9	5.2	3600	2	9 1/2	6 3/8	16	1.40
50UTZ2.75S	1	9.9	5.2	3600	2	9 1/2	11 5/8 ^{*1}	18 ^{*1}	1.40

(Suffix Z: Automatic Operation)

* Synchronous Speed

^{*1}: Minimum Required Space

UZ SERIES | Full-Vortex Cast Iron Impeller

Features a vortex impeller and wide pump casing interior, effectively pumping and discharging water containing solids and fibrous foreign matters.



UZ Series pump with elbow



With TOS Guide Rail System

Discharge Size: 2" - 3"

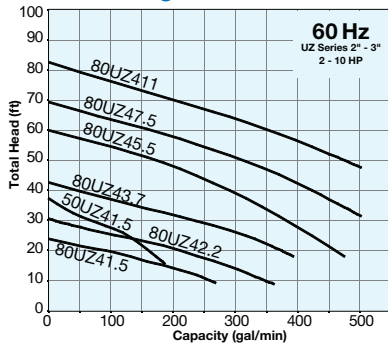

Discharge Size: 4"

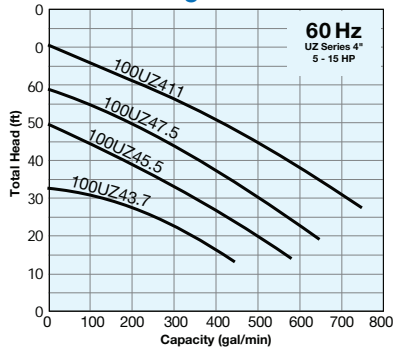

Dimension: Free Standing A / B / C

Dimension: Guide Rail Fitting (TO / TOS) D / E / F

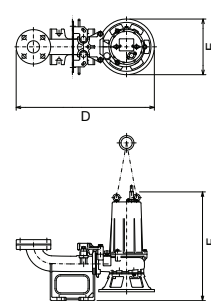
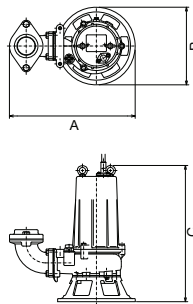

Three Phase Model	Motor Output (HP)	Rated Current (A)				*S.S. (RPM)	Discharge Size (in.)	Dimensions (in.)						Max. Solids Dia. (in.)
		208V	230V	460V	575V			Free Standing Models			TOS Guide Rail Models			
								A	B	C	D	E	F	
50UZ41.5	2	7.3	7.0	3.5	2.9	1800	2	15 15/16	9 3/4	22 5/16	24 7/16	9 3/4	24 5/8	1.97
80UZ41.5	2	7.3	7.0	3.5	2.9	1800	3	21 5/8	10 1/4	25 1/16	28 1/16	10 1/4	26 3/8	3.15
80UZ42.2	3	9.4	9.2	4.6	3.6	1800	3	21 5/8	10 1/4	25 1/16	28 1/16	10 1/4	26 3/8	3.15
80UZ43.7	5	14.8	14.2	6.9	5.4	1800	3	22 11/16	11 7/16	27 1/16	29 1/8	11 7/16	28 3/8	3.15
100UZ43.7	5	14.8	13.8	6.9	5.4	1800	4	25 1/2	12 3/8	29	33 11/16	12 3/8	30 9/16	3.94
80UZ45.5	7.5	22.6	20.5	10.3	8.1	1800	3	24 1/8	14 1/8	35 3/8	30 9/16	14 1/8	36 1/2	3.15
100UZ45.5	7.5	22.6	20.5	10.3	8.1	1800	4	26 7/16	14 1/8	36 15/16	34 11/16	14 1/8	38 3/8	3.94
80UZ47.5	10	28.8	26.6	13.4	10.8	1800	3	24 1/8	14 1/8	36 1/4	30 9/16	14 1/8	37 5/16	3.15
100UZ47.5	10	28.8	26.6	13.4	10.8	1800	4	26 7/16	14 1/8	37 13/16	34 11/16	14 1/8	39 3/16	3.94
80UZ411	15	41.4	38.0	19.0	14.7	1800	3	24 7/16	14 1/8	38 5/8	30 7/8	14 1/8	39 5/8	3.15
100UZ411	15	41.4	38.0	19.0	14.7	1800	4	26 3/4	14 1/8	40 3/16	35	14 1/8	41 1/2	3.94

* Synchronous Speed

MG SERIES | Semi-Vortex High Chrome Impeller

Tsurumi submersible grinder pumps utilize a grinding mechanism in the suction port to crush foreign matter into fine particles before discharging the waste. The pump utilizes a recessed vortex impeller that moves the fibrous matter without causing wear to the impeller.

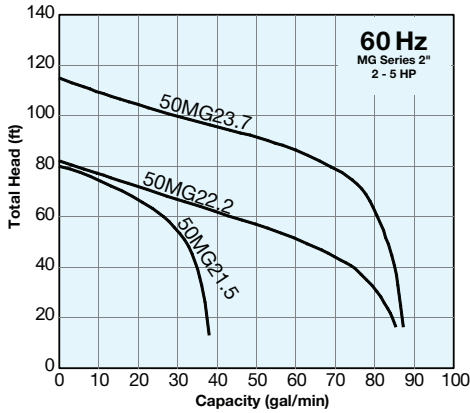

Grinding Mechanism

Dimension: Free Standing A / B / C Dimension: Guide Rail Fitting (T0 / TOS) D / E / F

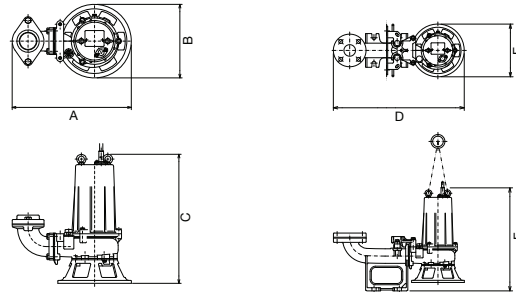

Three Phase Model	Motor Output (HP)	Rated Current (A)				*S.S. (RPM)	Discharge Size (in.)	Dimensions (in.)						Max. Solids Dia. (in.)
		208V	230V	460V	575V			Free Standing Models			TOS Guide Rail Models			
								A	B	C	D	E	F	
50MG21.5	2	6.7	6.6	3.3	2.6	3600	2	14 5/16	8 9/16	21 15/16	24 3/8	8 9/16	23 1/8	0.2
50MG22.2	3	10.0	9.8	4.9	3.8	3600	2	17 1/4	8 7/8	23 3/8	24 3/8	8 7/8	24 11/16	0.2
50MG23.7	5	14.4	13.6	6.8	5.3	3600	2	17 1/4	8 7/8	23 3/8	24 3/8	8 7/8	24 11/16	0.2

* Synchronous Speed

SQ SERIES | Compact & Lightweight Corrosion Resistant Pump

The SQ pump features a top discharge, flow-thru design with forced motor cooling that enables extended running at low water level. In addition, the SQ pump fits into an 8-inch pipe.

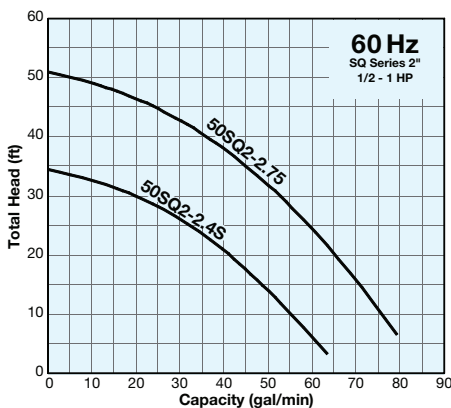

- It is made of 304 / 316 stainless steel, Nitrile Butadiene Rubber and special resin to stand up to rust and corrosion, and sport a new structural design that makes them even lighter and easier to carry
- Non-toxic white mineral oil used to lubricate mechanical seals
- Motor protector protects against overheating and run-dry
- Designed to fit into an 8-inch pipe



50SQ2-2.4S

Single Phase Model	Motor Output (HP)	Rated Current (A)		*S.S. (RPM)	Discharge Size (in.)	Dimensions (in.)			Max. Solids Dia. (in.)		
		115V	230V			Free Standing Models					
		A	B	C							
50SQ2-2.4S	1/2	5.1	2.9	3600	2	7 1/16	7 1/16	14 7/16	0.236		
Three Phase Model	Motor Output (HP)	Rated Current (A)				*S.S. (RPM)	Discharge Size (in.)	Dimensions (in.)			Max. Solids Dia. (in.)
		208V	220V	460V	575V			Free Standing Models			
		A	B	C							
50SQ2-2.75	1	3.4	3.5	2.0	1.5	3600	2	7 1/16	7 1/16	15 3/16	0.236

* Synchronous Speed

Dimension: Free Standing

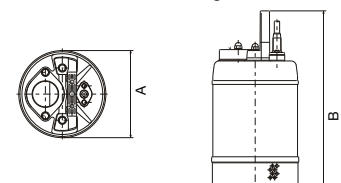

SFQ SERIES | Stainless Steel Pump

Submersible drainage/dewatering pump designed for corrosive liquids and atmospheres. All cast 316 Stainless Steel construction with viton elastomers and semi-open Stainless Steel impeller. Offered in three phase, 1 HP - 15 HP models at 208V - 230V, 460V and 575V & 2in., 3in. and 4in. discharge sizes.

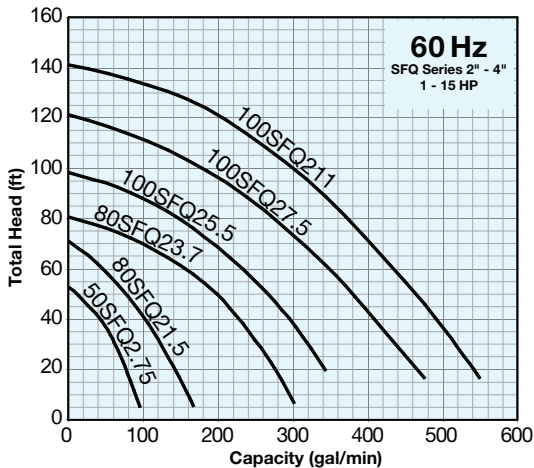

- All wetted material components are 316 Stainless Steel
- Dual inside mechanical seals with Silicon Carbide faces, running in an oil filled chamber and further protected by exclusionary lip seal, providing the most durable seal available
- Optional 316 Stainless Steel slide rail system is available for models from 7.5 HP - 15 HP
- Seal pressure relief system features an independent chamber separate from the oil casing in which the mechanical seal is housed
- Optional: High temperature winding (available on all series)

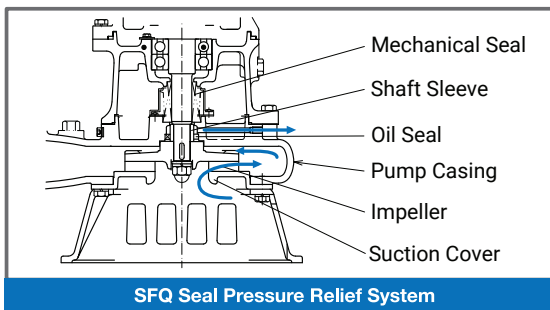

Dimension: Free Standing A / B / C

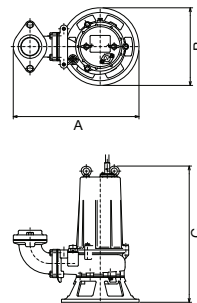

Dimension: Guide Rail Fitting (TO / TOS) D / E / F

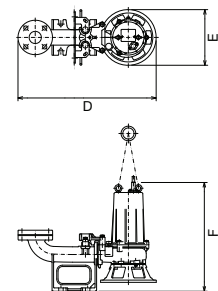

Three Phase Model	Motor Output (HP)	Rated Current (A)				*S.S. (RPM)	Discharge Size (in.)	Dimensions (in.)						Max. Solids Dia. (in.)
		208V	230V	460V	575V			Free Standing Models			TO Guide Rail Models			
								A	B	C	D	E	F	
50SFQ2.75	1	3.5	3.1	1.6	1.4	3600	2	9 15/16	7 11/16	15 11/16	N/A	N/A	N/A	0.24
80SFQ21.5	2	6.9	6.7	3.4	2.7	3600	3	12 15/16	8 11/16	19 1/16	N/A	N/A	N/A	0.24
80SFQ23.7	5	13.8	12.8	6.4	5.0	3600	3	14 1/8	10 1/8	21 5/16	N/A	N/A	N/A	0.59
100SFQ25.5	7.5	19.3	18.2	9.4	7.5	3600	4	25 3/8	14 3/16	33 1/4	37 3/16	14 3/16	35 7/8	0.79
100SFQ27.5	10	26.0	24.4	12.2	9.5	3600	4	25 3/8	14 3/16	33 1/4	37 3/16	14 3/16	35 7/8	0.79
100SFQ211	15	37.0	35.2	17.6	13.9	3600	4	25 3/8	14 3/16	35 1/8	37 3/16	14 3/16	37 13/16	0.91

* Synchronous Speed

AVANT® MQ SERIES | Highly Customizable Explosion Proof Pump

The AVANT MQ Series features a highly specifiable design for even more added benefits. Available in four impeller types - Open Channel, Chopper, Grinder, and Vortex - these variations allow for a wide range of applications and capabilities. Whether a wet or dry pit (with closed loop cooling jacket) configuration is needed, the MQ Series is the right choice. The many options available with the MQ Series of pumps are sure to meet the needs of the most challenging application.



MQ Series

Highly customizable explosion proof line of pumps

Motors

IE3 motors from 4 to 25 HP

Hydraulics

- Open Channel (MQB)
- Chopper (MQC)
- Grinder (MQG)
- Vortex (MQU)

MQB: Open Channel

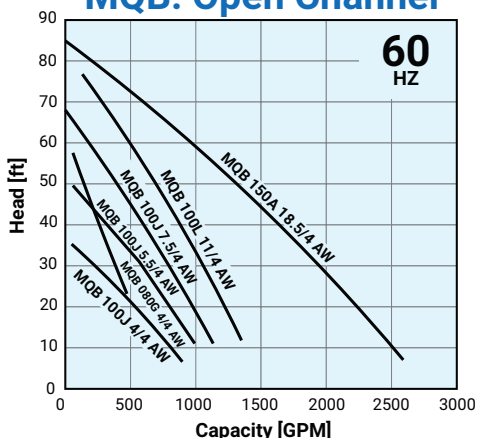

MQC: Chopper

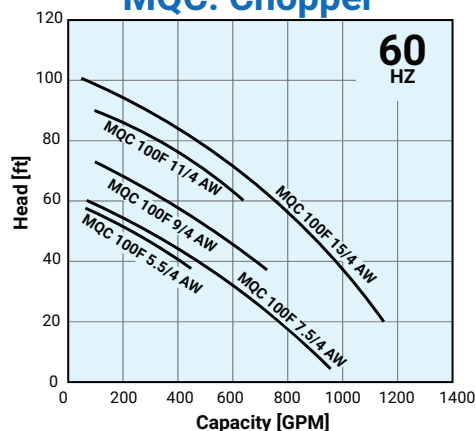

MQG: Grinder

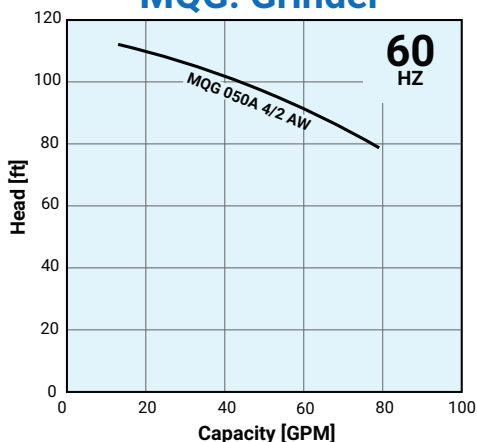

MQU: Vortex

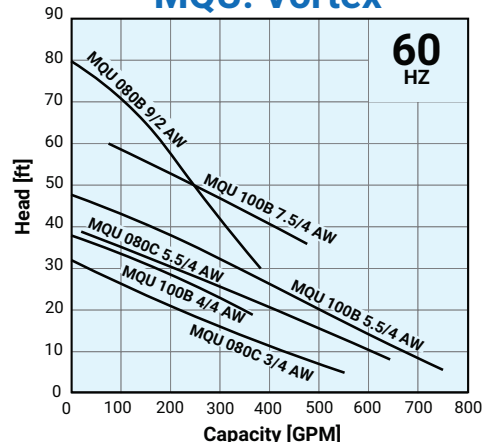

Specifications

MQB Series: Open Channel

Model	Motor Output (HP)	Rated Current (A)		*S.S. (rpm)	Discharge Size (in.)	Impeller Diameter (mm)	Max Head (ft)	Max Flow (gpm)	BEP Head (ft)	BEP Flow (gpm)	Dimensions (in.)			Free Passage (in.)
		230V	460V								H	W	D	
MQB 080G 4/4 AW	5.5	14.8	7.4	1800	3	195	57	480	37	307	35 1/2	15 1/2	12	2.95
MQB 100J 4/4 AW	5.5	14.8	7.4	1800	4	175	35	900	22	496	38	23 3/4	16	2.56
MQB 100J 5.5/4 AW	7.5	19.8	9.9	1800	4	195	50	1,000	31	581	38	23 3/4	16	2.56
MQB 100J 7.5/4 AW	10	25.6	12.8	1800	4	205	65	1,150	39	677	41	23 3/4	16	2.56
MQB 100L 11/4 AW	15	37.6	18.8	1800	4	220	77	1,350	50	733	46	21 3/4	16 1/2	2.36
MQB 150A 18.5/4 AW	25	61.6	30.8	1800	6	245	79	2,400	46	1,380	53 1/2	24 1/8	18 3/8	3.15

*Synchronous Speed

MQC Series: Chopper

Model	Motor Output (HP)	Rated Current (A)		*S.S. (rpm)	Discharge Size (in.)	Impeller Diameter (mm)	Max Head (ft)	Max Flow (gpm)	BEP Head (ft)	BEP Flow (gpm)	Dimensions (in.)			Free Passage (in.)
		230V	460V								H	W	D	
MQC 100F 5.5/4 AW	7.5	19.8	9.9	1800	4	190	58	450	48	270	38	23 3/4	16	1.77
MQC 100F 7.5/4 AW	10	25.6	12.8	1800	4	190	60	950	40	448	41	23 3/4	16	1.77
MQC 100F 9/4 AW	12	32.6	16.3	1800	4	210	73	725	49	540	44 1/2	23 3/4	16	1.77
MQC 100F 11/4 AW	15	37.6	18.8	1800	4	230	90	635	64	588	46 1/2	23 3/4	16 1/2	1.77
MQC 100F 15/4AW	20	48.8	24.4	1800	4	240	100	1,150	71	608	46 1/2	23 3/4	16 3/8	1.77

*Synchronous Speed

MQG Series: Grinder

Model	Motor Output (HP)	Rated Current (A)		*S.S. (rpm)	Discharge Size (in.)	Impeller Diameter (mm)	Max Head (ft)	Max Flow (gpm)	BEP Head (ft)	BEP Flow (gpm)	Dimensions (in.)			Free Passage (in.)
		230V	460V								H	W	D	
MQG 050A 4/2 AW	5.5	13.6	6.8	3600	2	140	112	80	80	80	29 1/2	14 1/4	11 1/4	-

*Synchronous Speed

MQU Series: Vortex

Model	Motor Output (HP)	Rated Current (A)		*S.S. (rpm)	Discharge Size (in.)	Impeller Diameter (mm)	Max Head (ft)	Max Flow (gpm)	BEP Head (ft)	BEP Flow (gpm)	Dimensions (in.)			Free Passage (in.)
		230V	460V								H	W	D	
MQU 080C 3/4 AW	4	11.6	5.8	1800	3	150	31	540	23	165	33 3/4	16	12 3/4	2.56
MQU 080C 5.5/4 AW	7.5	19.8	9.9	1800	3	165	39	640	29	221	37 3/4	16	12 3/4	2.56
MQU 080B 9/2 AW	12	29.2	14.6	3600	3	135	79	380	51	230	37 3/4	16	12 3/4	3.15
MQU 100B 4/4 AW	5.5	14.8	7.4	1800	4	165	37	350	24	272	39 1/2	19 1/2	14 3/4	3.94
MQU 100B 5.5/4 AW	7.5	19.8	9.9	1800	4	180	46	480	31	310	39 1/2	19 1/2	14 3/4	3.94
MQU 100B 7.5/4 AW	10	25.6	12.8	1800	4	200	60	475	41	391	42 1/2	19 1/2	14 3/4	3.94

*Synchronous Speed



MQ Series - Highly Customizable

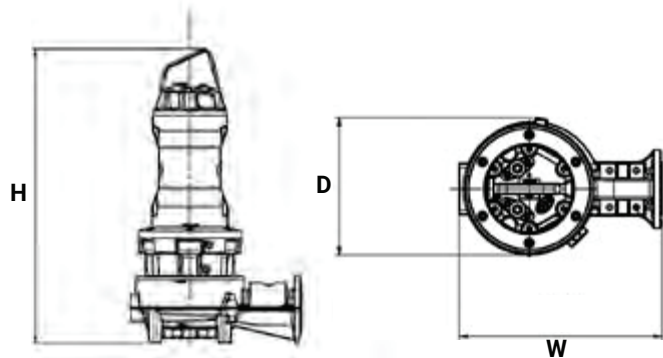

AVANT® MY SERIES | In Stock Explosion Proof Pumps

The AVANT MY Series features the same durable and reliable design with readily available inventory. The MY Series is available with four impeller options including the Open Channel, Chopper, Grinder, and Vortex. This powerful pump, like our MQ Series, can withstand the challenges posed by hazardous locations. The MY Series of pumps are the newest addition to our AVANT Line aimed at satisfying the immediate needs of our customers.



MY Series

In stock explosion proof series of pumps

Motors

From 2.5 to 20 HP

Hydraulics

- Open Channel (MYB)
- Chopper (MYCZ)
- Grinder (MYG)
- Vortex (MYU)



MYB
Open Channel



MYCZ
Chopper



MYG
Grinder



MYU
Vortex



MY Series - In Stock

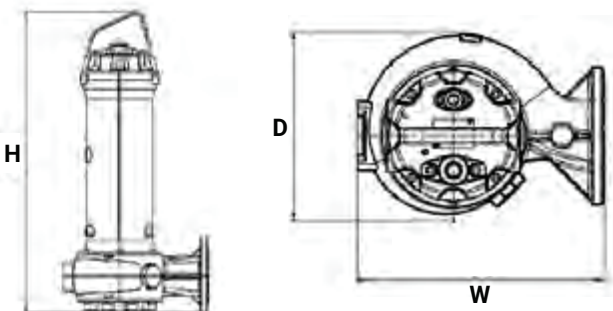

AVANT® MY SERIES | MYB - Open Channel Pump

MYB, explosion proof open channel solids handling pump. Designed for raw sewage and wastewater in municipal, industrial and commercial applications. The MYB open channel impeller maximizes free passage of solids. Clogging risk is minimized through the anti-clog spiral groove within the pump's suction plate. Offered in 3in. and 4in. discharge sizes with motor sizes up to 15 HP.



MYB: Open Channel (Stock)

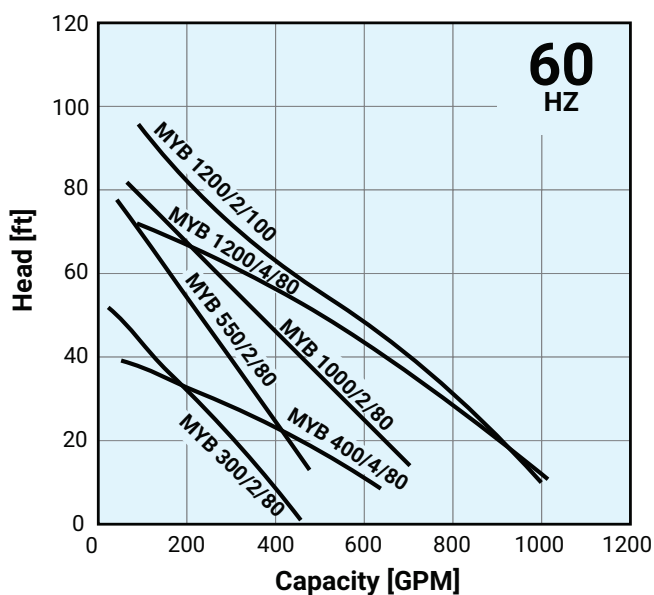

MYB: Open Channel (Non-Stock)

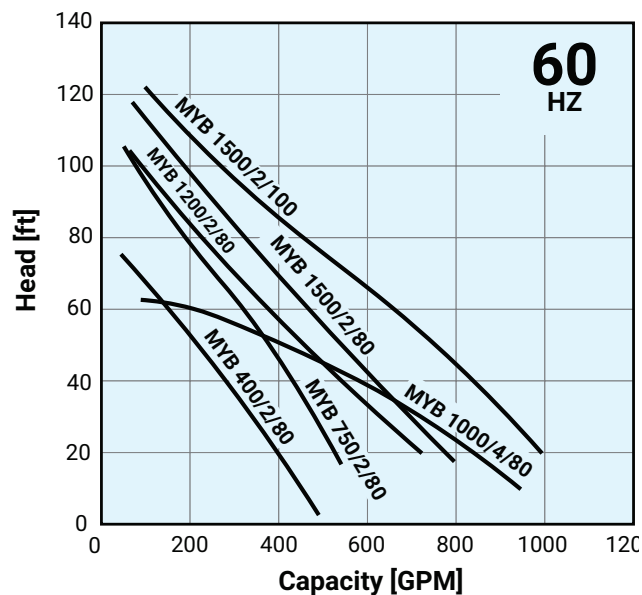

Model	Motor Output (HP)	Rated Current (A)		*S.S. (RPM)	Discharge Size (in.)	Max Head (ft)	Max Flow (gpm)	BEP Head (ft)	BEP Flow (gpm)	Dimensions (in.)			Free Passage (in.)
		230V	460V							H	W	D	
MYB 300/2/80	3	8.1	4.0	3600	3	52	460	28	225	22 1/2	13 1/2	10	1.38
MYB 400/2/80*	4	-	5.6	3600	3	75	490	47	230	24 1/2	13 1/2	10	1.18
MYB 400/4/80	4	11.7	5.9	1800	3	39	640	27	310	25 3/4	15 1/2	11 1/2	2.36
MYB 550/2/80	5.5	13.4	6.7	3600	3	78	480	46	260	26 3/4	13 1/2	10	1.57
MYB 750/2/80*	7.5	-	9.3	3600	3	105	540	61	300	26 3/4	13 1/2	10	1.57
MYB 1000/2/80	10	23.7	11.9	3600	3	83	700	46	370	30 7/8	13	11	1.97
MYB 1000/4/80*	10	-	13.9	1800	3	62	950	41	540	35 3/8	19 1/8	14 3/8	2.36
MYB 1200/2/80*	12	-	14.0	3600	3	104	730	62	370	33 3/8	13	11	1.97
MYB 1200/2/100	12	28.0	14.0	3600	4	96	1,000	48	610	33 5/8	16 3/8	12	1.77
MYB 1200/4/80	12	29.7	14.9	1800	3	72	1,020	48	550	38 1/2	19 1/8	14 3/8	2.36
MYB 1500/2/80*	15	-	16.9	3600	3	117	800	72	390	33 3/8	13	11	1.97
MYB 1500/2/100*	15	-	16.9	3600	4	122	1,050	65	610	33 5/8	16 3/8	12	1.77

*Non-Stock. Only Available In 460V.

*Synchronous Speed

AVANT® MY SERIES | MYCZ - Chopper Pump

MYCZ, explosion proof solids handling chopper pump. Designed for municipal, industrial and commercial applications prone to fibrous solids. The chopping mechanism is formed by the rotating screw type channel impeller against the cast sharp tooth on the suction plate. Offered in 3in. and 4in. discharge sizes with motor sizes up to 20 HP.

MYCZ: Chopper (Stock)

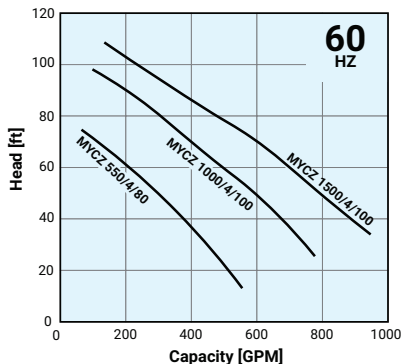

MYCZ: Chopper (Non-Stock)

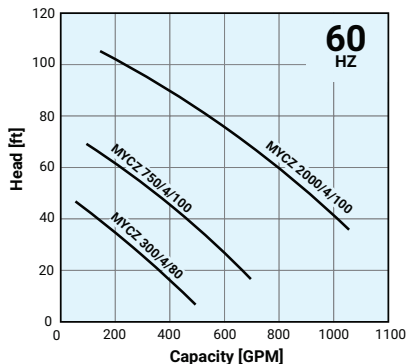

FM
APPROVED

Model	Motor Output (HP)	Rated Current (A)		*S.S. (RPM)	Discharge Size (in.)	Max Head (ft)	Max Flow (gpm)	BEP Head (ft)	BEP Flow (gpm)	Dimensions (in.)			Free Passage (in.)
		230V	460V							H	W	D	
MYCZ 300/4/80*	3	-	4.6	1800	3	47	495	28	270	25 1/4	16	13 3/8	1.26
MYCZ 550/4/80	5.5	14.8	7.4	1800	3	62	555	40	300	30 3/8	16	13 3/8	1.18
MYCZ 750/4/100*	7.5	-	10.4	1800	4	69	690	42	430	31	18 5/8	16 1/8	1.42
MYCZ 1000/4/100	10	27.8	13.9	1800	4	82	780	52	470	33 3/4	18 5/8	16 1/8	1.34
MYCZ 1500/4/100	15	35.6	17.8	1800	4	90	950	56	635	38 1/2	19 1/2	16 3/8	1.73
MYCZ 2000/4/100*	20	-	26.9	1800	4	105	1,060	69	695	42	19 1/2	16 3/8	1.65

*Non-Stock. Only Available In 460V.

*Synchronous Speed

AVANT® MY SERIES | MYG - Grinder Pump

MYG, explosion proof solids handling grinder pump. Designed for high pressure small diameter piping within municipal, industrial and commercial applications. Solids are cut into fine particles by the chromium tri-blade grinder mechanism and moved through the pump via multi-channel impeller. Offered in 2in. discharge size with motor sizes up to 10 HP.

MYG: Grinder (Stock)

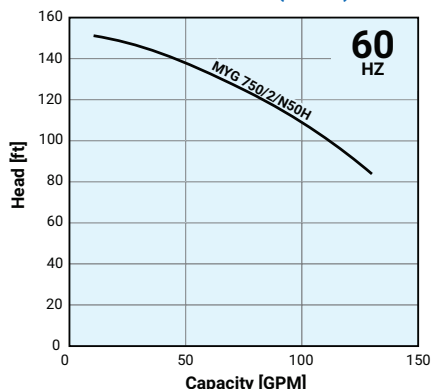

MYG: Grinder (Non-Stock)

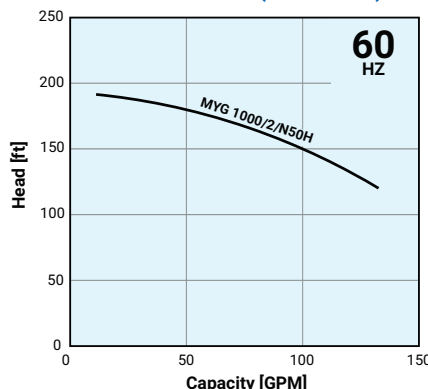

FM
APPROVED

Model	Motor Output (HP)	Rated Current (A)		*S.S. (RPM)	Discharge Size (in.)	Max Head (ft)	Max Flow (gpm)	BEP Head (ft)	BEP Flow (gpm)	Dimensions (in.)			Free Passage (in.)
		230V	460V							H	W	D	
MYG 750/2/N50H	7.5	18.5	9.3	3600	2	151	127	112	95	25 3/4	14	10 3/8	-
MYG 1000/2/N50H*	10	-	11.9	3600	2	191	132	143	110	28 5/8	14	10 3/8	-

*Non-Stock. Only Available In 460V.

*Synchronous Speed

AVANT® MY SERIES | MYU - Vortex Pump

Tsurumi's explosion-proof vortex pump. Designed for water circulation, civil lift stations, and storm water drainage systems. Open space within the pump volute maximizes free passage while minimizing abrasive wear on the impeller. Offered in 2.5in. to 4in. discharge sizes with motor sizes up to 12 HP.



MYU: Vortex (Stock)

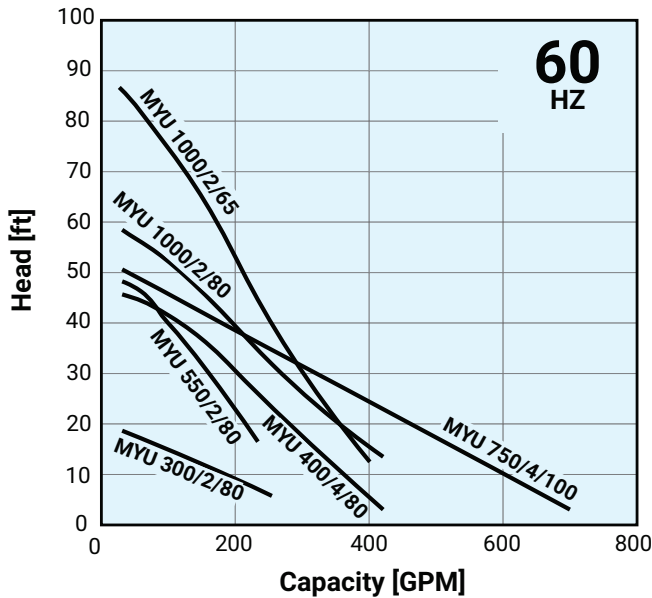

MYU: Vortex (Non-Stock)

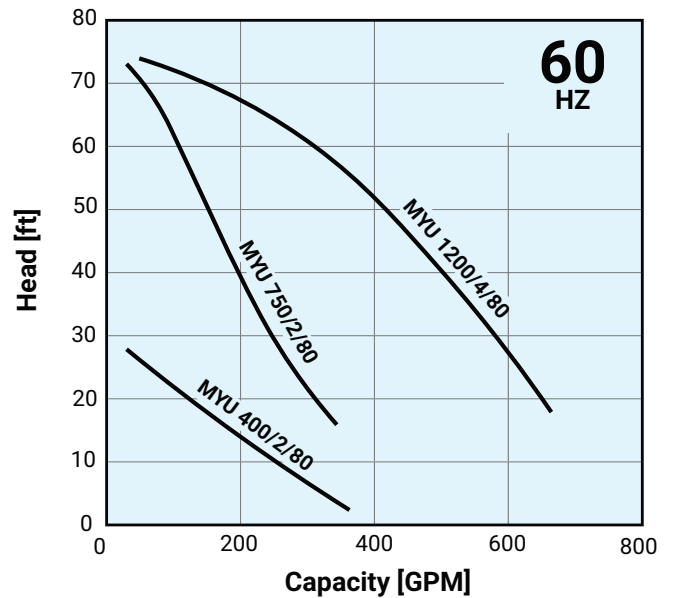

Model	Motor Output (HP)	Rated Current (A)		*S.S. (RPM)	Discharge Size (in.)	Max Head (ft)	Max Flow (gpm)	BEP Head (ft)	BEP Flow (gpm)	Dimensions (in.)			Free Passage (in.)
		230V	460V							H	W	D	
MYU 300/2/80	3	8.1	4.0	3600	3	19	260	12	160	23 3/4	12 3/8	9 1/8	3.15
MYU 400/2/80*	4	-	5.6	3600	3	29	365	15	185	25 3/4	12 1/4	9 1/8	3.15
MYU 400/4/80	4	11.7	5.9	1800	3	46	460	32	185	27 1/4	15 3/8	12	3.15
MYU 550/2/80	5.5	13.4	6.7	3600	3	48	230	31	140	29 3/8	12 1/2	10	2.56
MYU 750/2/80*	7.5	-	9.3	3600	3	73	345	44	185	28	12 5/8	9 3/4	2.68
MYU 750/4/100	7.5	20.9	10.4	1800	4	51	700	34	220	33	16 1/8	12	3.15
MYU 1000/2/65	10	23.7	11.9	3600	2.5	87	400	60	160	31 7/8	12	9	2.56
MYU 1000/2/80	10	23.7	11.9	3600	3	59	420	39	200	32 1/4	12 1/2	10	3.15
MYU 1200/4/80*	12	-	14.9	1800	3	74	665	57	340	38 5/8	19 1/8	14 3/4	2.36

*Non-Stock. Only Available In 460V.

*Synchronous Speed

AVANT® MMR SERIES | Explosion Proof Mixers

The AVANT MMR Series is a new line of submersible mixers that features an FM approved design and premium IE3 motors. They have been designed to operate over a wide range of applications. Optional motor and mounting configurations available.



MMR Series

Explosion proof line of mixers

Cast iron – Premium efficiency IE3 motors

DIRECT TRANSMISSION

- Propeller Ø 200 - 300 - 400 mm
- Motor power 1.5 - 6 HP
- 4, 6, and 8 pole motors

REDUCTION GEARS

- Propeller Ø 650 mm
- Motor power 5-10 HP
- 4 pole motors

The AVANT® MMR Series offers a wide range of accessories for adjusting the mixer's position in the tank. With assistance from lifting equipment, these accessories are designed for easy installation, positioning, and removal of the mixer. Accessories are available in galvanized or stainless steel.

The recommended installation methods are:

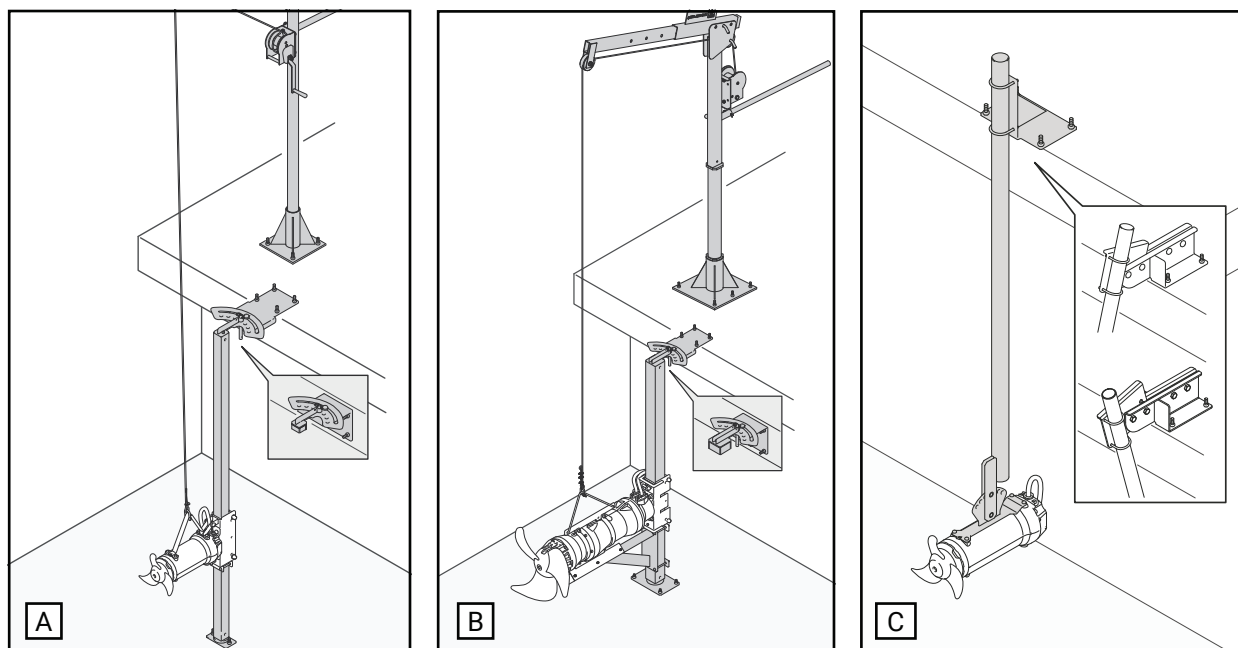

Mast installation (fig. A and B)

The most common installation type for mixers of any shape and size. The mixer, fitted with a universal mounting bracket, slides along a square post for easy removal and required horizontal positioning. Vertical adjustments can be made with an additional mounting bracket.

Pendular installation (fig. C)

Installation in which the mixer can be both installed and removed while the tank is full. The mixer is suspended from a pipe that is fixed to a mounting bracket. It can be adjusted both horizontally and vertically.

Materials

	Standard
Motor Housing	EN-GJL 250 gray cast iron
Propeller	AISI 316 stainless steel
Shaft	AISI 431 stainless steel
Mechanical Seals	Silicon carbide
Hardware	A2-70 stainless steel
Gaskets	NBR
Lifting Hook	AISI 304 stainless steel
Motor Bracket	AISI 304 stainless steel
Paint	Bicomponent epoxy paint 7.8 thou

Specifications

Direct Drive

Model	Motor Output (hp)	Rated Current (A)		*S.S. (rpm)	Reduction Ratio	Output Speed (rpm)	Propeller Diameter (mm)	Thrust (lbf)	Weight (lbs)	Mounting Bracket (in.)	Dimensions (in.)		
		230V	460V								L	W	Dia.
MMR21NF41.1D-6	1.5	4.8	2.4	1800	-	1800	200	51	78	2 x 2	18 5/8	7 7/8	8 1/4
MMR21NF41.5D-6	2	6.6	3.3	1800	-	1800	200	52	80	2 x 2	18 5/8	7 7/8	8 1/4
MMR33NF61.5D-6	2	6.6	3.3	1200	-	1200	300	94	106	2 x 2	26 5/8	18 5/8	11 7/8
MMR31NF62.2D-6	3	9.8	4.9	1200	-	1200	300	136	126	2 x 2	30	18 5/8	11 7/8
MMR32NF63.2D-6	4	12.6	6.3	1200	-	1200	300	164	175	2 x 2	32	20 3/4	12
MMR42NF84.5D-6	6	18.8	9.4	900	-	900	400	218	272	4 x 4	37 1/2	38 7/8	15 3/4

*Synchronous Speed

Gear Reduced

Model	Motor Output (hp)	Rated Current (A)		*S.S. (rpm)	Reduction Ratio	Output Speed (rpm)	Propeller Diameter (mm)	Thrust (lbf)	Weight (lbs)	Mounting Bracket (in.)	Dimensions (in.)		
		230V	460V								L	W	Dia.
MMR61NF44.0G072-6	5	14.8	7.4	1800	7.2	250	650	0.31	320	4 x 4	47 1/2	38 7/8	25 5/8
MMR61NF45.5G066-6	7	19.8	9.9	1800	6.6	273	650	0.34	327	4 x 4	47 1/2	38 7/8	25 5/8
MMR61NF47.5G058-6	10	25.6	12.8	1800	5.8	310	650	0.47	406	4 x 4	48 1/2	39 3/4	25 5/8

*Synchronous Speed



MMR Series - FM Approved Mixers

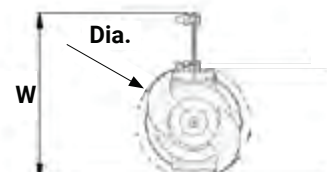
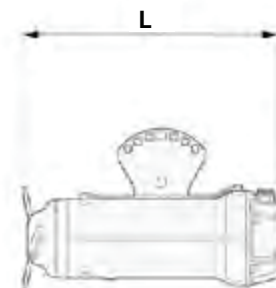

VANCS™ : OM•PN•PSF•PU•TM SERIES | Corrosion Resistant Submersible Pump

The VANCS™ - OM, PU, PN, PSF and TM Series submersible pump is designed for handling raw sewage, wastewater, as well as industrial and commercial sump pump applications. The VANCS™ pumps have a proven track record for offering long lifecycles in both continuous and intermittent sump applications. With the pump made of complete molded resin material and all other parts coming in contact with the pump liquid in either 304 Stainless Steel or Titanium.

VANCS™



- Residential, commercial, industrial, effluent, wastewater and site drainage
- Chemical spill containment
- Raw water supply from rivers or lakes
- For TM Series: Titanium components increases corrosion resistance in a wide variety of applications. Ideal use for salt wastewater, site drainage and bilge pumps
- Automatic Operation (A) and Auto Alternating Operation (W) are available

✓ VANCS™ Pumps: TOK Guide Rail Fitting System

The TOK guide rail fitting system connects the pump to and from the piping easily just by lowering and hoisting the pump, allowing easy maintenance and inspection without the need to enter the sump.

Made of high-quality resin, the TOK is designed for lightweight, small to middle sized pumps. Rubber bellows attached to the guide hook are inverted to the duckfoot bend when the pump starts operating, and it seals by the pumping pressure. This eliminates leakage at the seal even if a lightweight pump is used in combination with the TOK.

The TOK is available in all motor output ranges of the PU, PN, and PSF Series.

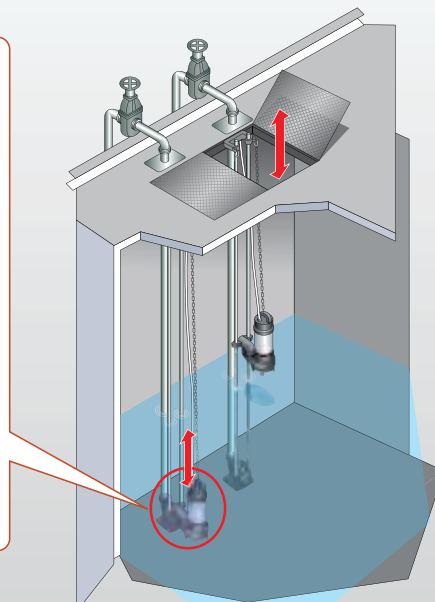
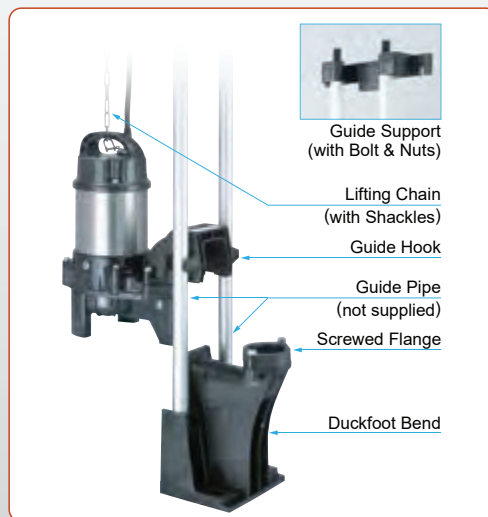

✓ Automatic & Auto-Alternation Models

The VANCS™ pumps are available with automatic duplexing (suffix "A") capabilities eliminating the need for a duplexing control panel*. The auto-alternating model has three floats and can be identified by the suffix "W". Refer to standard specifications for availability and model numbers. It is available in the same output range of the automatic pumps.

*Note: Must be installed in accordance with all National or Local Electrical or Building Codes.



PNA: Automatic (A) Model

PUW: Auto-alternation (W) Model

✓ VANCS™ Pumps: Selection Table

Category	Series	Discharge Size inch	Impeller	Model	Motor Output HP							
					1/5	1/3	1/2	1	2	3	5	
Wastewater	OM	1.5	Vortex	Standard	✓							
				Automatic (A)	✓							
Wastewater	PN	2 – 3	Vortex	Standard		✓	✓	✓	✓	✓	✓	✓
				Automatic (A)		✓	✓	✓	✓	✓	✓	✓
				Auto-alternation (W)		✓	✓	✓	✓	✓	✓	✓
Wastewater -High Head-	PSF	2 – 3	Closed	Standard		✓	✓	✓	✓	✓	✓	✓
				Automatic (A)		✓	✓	✓	✓	✓	✓	✓
				Auto-alternation (W)		✓	✓	✓	✓	✓	✓	✓
Sewage	PU	2– 3	Vortex	Standard	✓	✓	✓	✓	✓	✓	✓	✓
				Automatic (A)	✓	✓	✓	✓	✓	✓	✓	✓
				Auto-alternation (W)	✓	✓	✓	✓	✓	✓	✓	✓
Seawater	TM	2 – 3	Vortex	Standard		✓	✓	✓	✓	✓	✓	✓
				Automatic (A)		✓	✓	✓	✓	✓	✓	✓

✓ VANCS™ Pumps: Type of Impeller

Vortex



The vortex impeller is adopted in every series except for the PSF Series. Rotation of the impeller produces a whirling, centrifugal action between the impeller and the pump casing, and it moves the fluid through the pump. Being coupled with a wide pump casing, wastewater containing solid matters can be pumped out without obstruction.

Closed



The closed impeller is adopted in the PSF Series. The impeller is also referred to as shrouded impeller, as it has circular shrouds at both sides of the impeller vanes. Although the pump has a limited solids passage capability, it can be used for higher pumping head applications.

VANCS™ Pumps Group Curves

OM Series

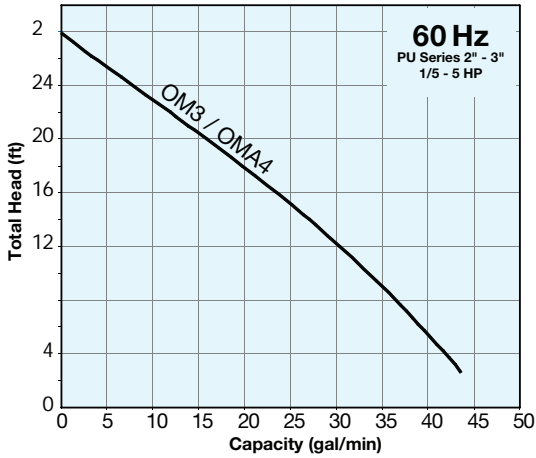

PN Series

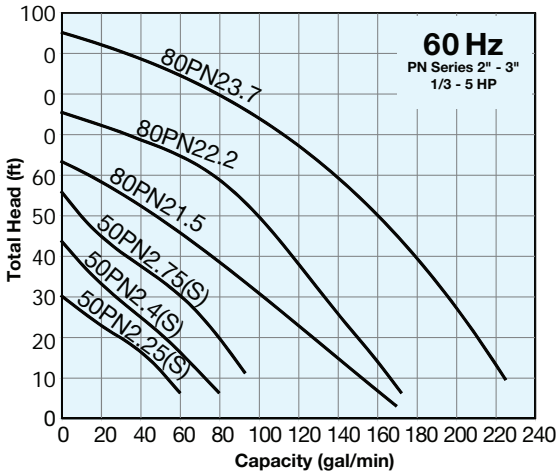

PSF Series

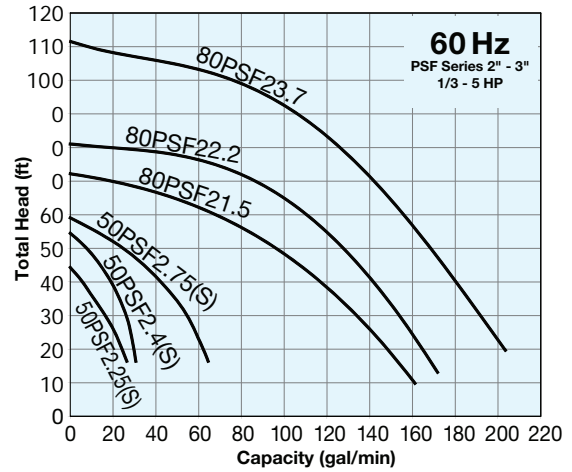

PU Series

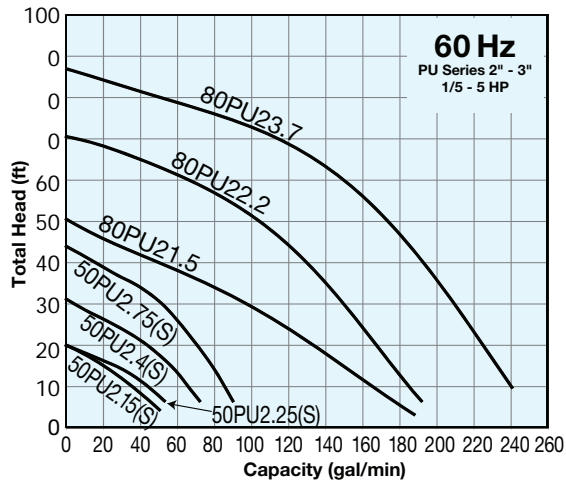

TM Series

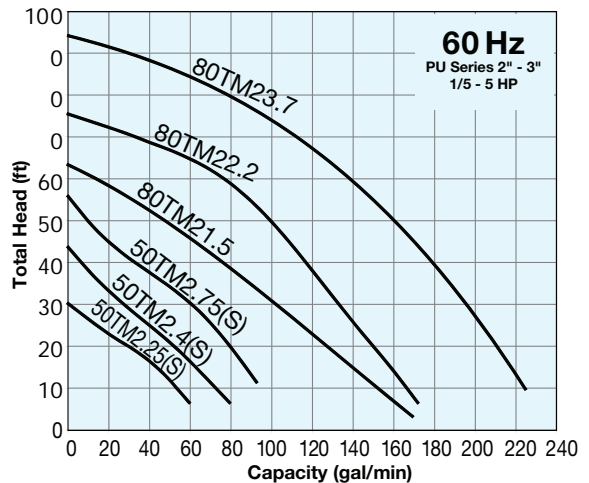

VANCS™ Pumps Specifications

* S.S. = Synchronous Speed

OM Series	Single Phase Model	Motor Output (HP)	Rated Current (A)		*S.S. (RPM)	Discharge Size (in.)	Dimensions (in.)			Max. Solids Dia. (in.)
			115V	230V			Free Standing Models			
							A	B	C	
	OM3 ★	1/5	3.2	1.6	3600	1.5	8	5 1/2	12 7/16	0.394
	OMA3 ★	1/5	3.2	1.6	3600	1.5	8	7	12 11/16	0.394

★ For VANCS™ pumps 1 HP and smaller: These pumps should not be operated on a VFD. Contact factory for more information.

Automatic (A) Options Available

PN Series	Single Phase Model	Motor Output (HP)	Rated Current (A)				*S.S. (RPM)	Discharge Size (in.)	Dimensions (in.)						Max. Solids Dia. (in.)
			115V		230V				Free Standing Models			TOK Guide Rail Models			
			A	B	C	D			E	F					
	50PN2.25S ★	1/3	4.6	2.3	3600	2	2	9 5/16	6 3/8	14 3/16	17 1/8	6 3/8	15 3/16	0.394	
	50PN2.4S ★	1/2	5.8	2.9	3600	2	2	9 5/16	6 3/8	14 3/16	17 1/8	6 3/8	15 3/16	0.394	
	50PN2.75S ★	1	9.2	4.6	3600	2	2	9 5/16	6 3/8	14 15/16	17 1/8	6 3/8	16	0.394	
	Three Phase Model	Motor Output (HP)	Rated Current (A)				*S.S. (RPM)	Discharge Size (in.)	Dimensions (in.)						Max. Solids Dia. (in.)
			208V	220V	460V	575V			Free Standing Models			TOK Guide Rail Models			
			A	B	C	D			E	F					
	50PN2.25 ★	1/3	1.65	1.6	0.75	---	3600	2	9 5/16	6 3/8	13 3/4	17 1/8	6 3/8	14 3/4	0.394
	50PN2.4 ★	1/2	2.1	2.0	0.95	---	3600	2	9 5/16	6 3/8	14 3/16	17 1/8	6 3/8	15 3/16	0.394
	50PN2.75 ★	1	3.2	3.2	1.5	---	3600	2	9 5/16	6 3/8	14 3/4	17 1/8	6 3/8	15 3/4	0.394
	80PN21.5	2	6.9	6.6	*3.6	---	3600	3	11 5/8	7 11/16	17 1/8	20 3/8	7 11/16	19 1/4	0.787
	80PN22.2	3	9.1	8.5	4.2	3.3	3600	3	12 1/4	8 3/8	22	21 5/16	8 3/8	23 3/8	0.787
	80PN23.7	5	14.4	13.4	6.5	5.0	3600	3	12 1/4	8 3/8	23 3/8	21 5/16	8 3/8	24 3/4	0.787

*440V

Automatic (A) & Auto-alternation (W) Options Available

Dimension: Free Standing (PU, PN, PSF, TM, OM Series)

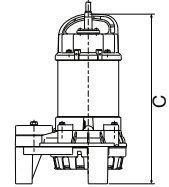
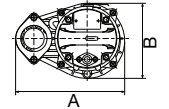

PSF Series	Single Phase Model	Motor Output (HP)	Rated Current (A)				*S.S. (RPM)	Discharge Size (in.)	Dimensions (in.)						Max. Solids Dia. (in.)
			115V		230V				Free Standing Models			TOK Guide Rail Models			
			A	B	C	D			E	F					
	50PSF2.25S ★	1/3	4.6	2.3	3600	2	2	9 5/16	6 3/8	14 3/16	17 1/8	6 3/8	15 3/16	0.315	
	50PSF2.4S ★	1/2	5.8	2.9	3600	2	2	9 5/16	6 3/8	14 3/16	17 1/8	6 3/8	15 3/16	0.315	
	50PSF2.75S ★	1	9.2	4.6	3600	2	2	9 5/16	6 3/8	14 15/16	17 1/8	6 3/8	16	0.315	
	Three Phase Model	Motor Output (HP)	Rated Current (A)				*S.S. (RPM)	Discharge Size (in.)	Dimensions (in.)						Max. Solids Dia. (in.)
			208V	220V	460V	575V			Free Standing Models			TOK Guide Rail Models			
			A	B	C	D			E	F					
	50PSF2.25 ★	1/3	1.65	1.6	0.75	---	3600	2	9 5/16	6 3/8	13 3/4	17 1/8	6 3/8	14 3/4	0.315
	50PSF2.4 ★	1/2	2.1	2.0	0.95	---	3600	2	9 5/16	6 3/8	14 3/16	17 1/8	6 3/8	15 3/16	0.315
	50PSF2.75 ★	1	3.2	3.2	1.5	---	3600	2	9 5/16	6 3/8	14 3/4	17 1/8	6 3/8	15 3/4	0.315
	80PSF21.5	2	6.9	6.6	*3.6	---	3600	3	11 5/8	7 11/16	17 1/8	20 3/8	7 11/16	19 1/4	0.512
	80PSF22.2	3	9.1	8.5	4.2	3.3	3600	3	12 1/4	8 3/8	22	21 5/16	8 3/8	23 3/8	0.512
	80PSF23.7	5	14.4	13.4	6.5	5.0	3600	3	12 1/4	8 3/8	23 3/8	21 5/16	8 3/8	24 3/4	0.512

*440V

Automatic (A) & Auto-alternation (W) Options Available

Dimension: Free Standing (PUF2.15S, OMA4)

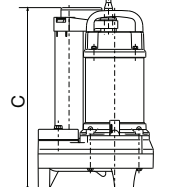
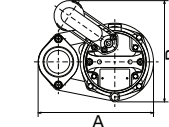

PU Series	Single Phase Model	Motor Output (HP)	Rated Current (A)				*S.S. (RPM)	Discharge Size (in.)	Dimensions (in.)						Max. Solids Dia. (in.)
			115V		230V				Free Standing Models			TOK Guide Rail Models			
			A	B	C	D			E	F					
	50PU2.15S ★	1/5	3.2	1.6	3600	2	2	8 7/8	6 1/16	14 13/16	17 1/8	6 1/16	16 1/8	1.38	
	50PU2.25S ★	1/3	4.6	2.3	3600	2	2	9 5/16	6 3/8	14 3/16	17 1/8	6 3/8	15 3/16	1.38	
	50PU2.4S ★	1/2	5.8	2.9	3600	2	2	9 5/16	6 3/8	14 3/16	17 1/8	6 3/8	15 3/16	1.38	
	50PU2.75S ★	1	9.2	4.6	3600	2	2	9 5/16	6 3/8	14 15/16	17 1/8	6 3/8	16	1.38	
	Three Phase Model	Motor Output (HP)	Rated Current (A)				*S.S. (RPM)	Discharge Size (in.)	Dimensions (in.)						Max. Solids Dia. (in.)
			208V	220V	460V	575V			Free Standing Models			TOK Guide Rail Models			
			A	B	C	D			E	F					
	50PU2.25 ★	1/3	1.65	1.6	0.75	---	3600	2	9 5/16	6 3/8	13 3/4	17 1/8	6 3/8	14 3/4	1.38
	50PU2.4 ★	1/2	2.1	2.0	0.95	---	3600	2	9 5/16	6 3/8	14 3/16	17 1/8	6 3/8	15 3/16	1.38
	50PU2.75 ★	1	3.2	3.2	1.5	---	3600	2	9 5/16	6 3/8	14 3/4	17 1/8	6 3/8	15 3/4	1.38
	80PU21.5	2	6.9	6.6	*3.6	---	3600	3	11 5/8	7 11/16	18 11/16	20 3/8	7 11/16	19 1/4	1.81
	80PU22.2	3	9.1	8.5	4.2	3.3	3600	3	12 1/4	8 3/8	22 15/16	21 5/16	8 3/8	23 3/8	1.81
	80PU23.7	5	14.4	13.4	6.5	5.0	3600	3	12 1/4	8 3/8	24 5/16	21 5/16	8 3/8	24 3/4	1.81

*440V

Automatic (A) & Auto-alternation (W) Options Available

Dimension: Guide Rail Fitting TOK (PU, PN, PSF, TM Series)

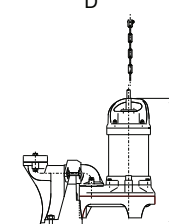
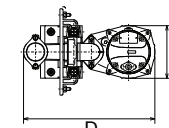

TM Series	Single Phase Model	Motor Output (HP)	Rated Current (A)				*S.S. (RPM)	Discharge Size (in.)	Dimensions (in.)						Max. Solids Dia. (in.)
			115V		230V				Free Standing Models			TOK Guide Rail Models			
			A	B	C	D			E	F					
	50TM2.25S ★	1/3	4.6	2.3	3600	2	2	9 5/16	6 3/8	14 3/16	N/A	N/A	N/A	0.394	
	50TM2.4S ★	1/2	5.8	2.9	3600	2	2	9 5/16	6 3/8	14 3/16	N/A	N/A	N/A	0.394	
	50TM2.75S ★	1	9.2	4.6	3600	2	2	9 5/16	6 3/8	14 15/16	N/A	N/A	N/A	0.394	
	Three Phase Model	Motor Output (HP)	Rated Current (A)				*S.S. (RPM)	Discharge Size (in.)	Dimensions (in.)						Max. Solids Dia. (in.)
			208V	220V	460V	575V			Free Standing Models			TOK Guide Rail Models			
			A	B	C	D			E	F					
	50TM2.25 ★	1/3	1.65	1.6	0.75	---	3600	2	9 5/16	6 3/8	13 3/4	N/A	N/A	N/A	0.394
	50TM2.4 ★	1/2	2.1	2.0	0.95	---	3600	2	9 5/16	6 3/8	14 3/16	N/A	N/A	N/A	0.394
	50TM2.75 ★	1	3.2	3.2	1.5	---	3600	2	9 5/16	6 3/8	14 3/4	N/A	N/A	N/A	0.394
	80TM21.5	2	6.9	6.6	*3.6	---	3600	3	11 5/8	7 11/16	17 1/8	N/A	N/A	N/A	0.787
	80TM22.2	3	9.1	8.5	4.2	3.3	3600	3	12 1/4	8 3/8	22	N/A	N/A	N/A	0.787
	80TM23.7	5	14.4	13.4	6.5	5.0	3600	3	12 1/4	8 3/8	23 3/8	N/A	N/A	N/A	0.787

*440V

Automatic (A) Options Available

CONTROL PANELS & MOISTURE DETECTOR

■ TS SERIES CONTROL PANELS



- Lockable – 4X Enclosures
- HOA Switch – Heavy Duty Oil Tight
- Terminal Block – For Field Wiring
- Pump Run Indicator – Heavy Duty Oil Tight
- Multi-Tap Control Transformer 208 / 230 / 460 VAC Operation
- Control Alarm Fuse
- Motor Protective Switch
- Adjustable Overload Protection
- IEC Rated Magnetic Contactor
- Horn Silence Switch – Heavy Duty Oil Tight
- Auto Reset Horn Silence
- Buzzer – 95db warble
- Red Alarm Beacon
- Includes three (3) Mechanical Float Switches & Pipe Clamp

■ SEAL MOISTURE PROBE

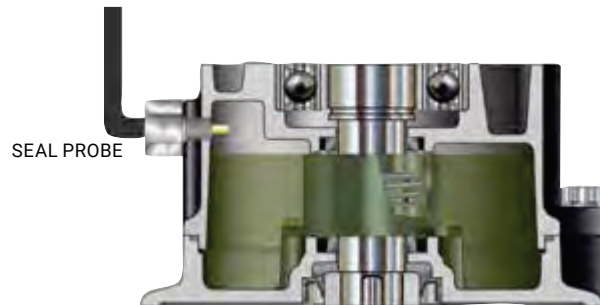

The **TSMP SEAL MOISTURE PROBE** is designed to detect moisture in the mechanical seal chamber, alerting customers of potential motor failure. The TSMP SEAL MOISTURE PROBE can be field installed on any new or existing Tsurumi pump models and connected to the control panel for the appropriate alarm or notification.

Principle of Operation:

- Sensor is installed through the oil port and directly into the mechanical seal chamber which contains an electrically non-conductive oil.
- The presence of water changes the chamber fluid mixture to a conductive condition and therefore completes the circuit which will result in a leakage indication on the control panel.

Electrical Specification

Sensor Type:	Conductive
Suggested Seal Fail Relay Voltage:	24 VAC
Required Wiring:	Single wire in separate sensor cable to be connected to seal leak relay in control panel by customer.

