



MILLER
SALES & ENGINEERING INC.

HI-PM CHECK VALVE

HI-PM Check Valve is a non-slam, spring-assisted, high pressure check valve designed for various fluids and temperatures. Due to its construction it is a low-maintenance option for high pressure applications.

The check valve is available in a variety of sizes and options.

- Connection standard is grooved pipe end in sizes 4in – 12in
- Standard metallurgy is Ductile Iron
- 1045 Carbon steel also available

Disc materials available:

- Neoprene
- Buna

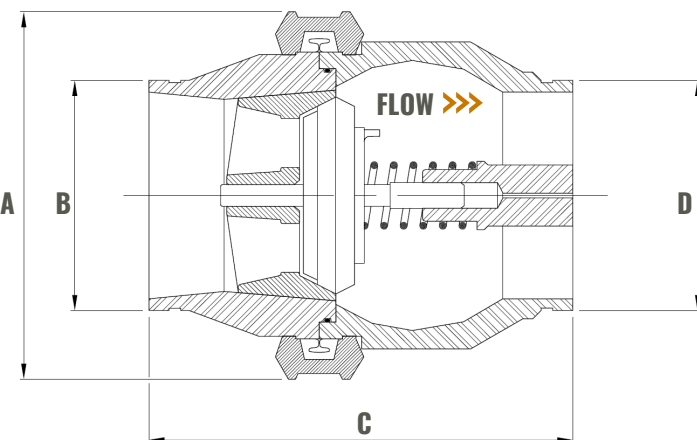

DIMENSIONS

Valve sizes B to D	General dimensions - Inches				Unit weight LBS	Pressure rating PSI
	A	B	C	D		
6 X 6	14 3/8	6 5/8	14	6 5/8	112	800
6 X 8	16 3/4	6 5/8	15 7/8	8 5/8	175	800
8 X 8	16 3/4	8 5/8	15 1/4	8 5/8	190	800
8 X 10	18 5/8	8 5/8	18	10 3/4	260	800
10 X 10	18 5/8	10 3/4	18	10 3/4	288	800
10 X 12	18 5/8	10 3/4	18	12 3/4	332	800
12 X 12	18 5/8	12 3/4	20	12 3/4	385	800

HI-PM CHECK VALVE

PARTS LIST

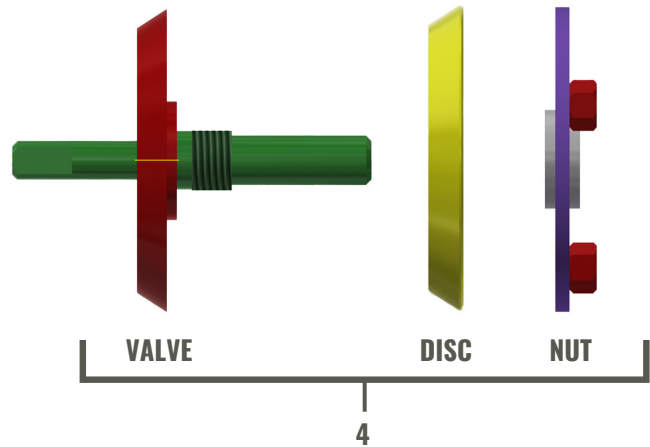
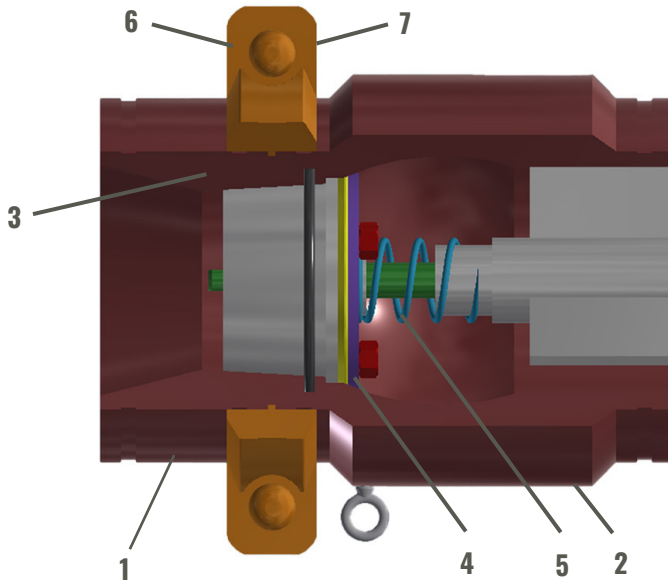

Valve size inches	1	2	3	4			5	6	7
	Inlet housing	Outlet housing	Seat	Valve assembly or parts			Spring	Cplg/W Gasket	"O" Ring
				Valve	Disc	Nut			
12 X 12	1212-1	1212-2	1010-3	1010-4A	1010-B	1010-C	1212-5	1010-6	1010-7
10 X 12	1010-1	1012-2	1010-3	1010-4A	1010-4B	1010-4C	1010-5	1010-6	1010-7
10 X 10	1010-1	1010-2	1010-3	1010-4A	1010-4B	1010-4C	1010-5	1010-6	1010-7
8 X 10	810-1	1010-2	1010-3	1010-4A	1010-4B	1010-4C	1010-5	1010-6	1010-7
8 X 8	808-1	808-2	808-3		808-4		808-5	808-6	808-7
6 X 8	608-1	808-2	808-3		808-4		808-5	808-6	808-7
6 X 6	606-1	606-2	606-3		606-4		606-5	606-6	606-7
4 X 6	406-1	606-2	606-3		606-4		606-5	606-6	606-7
4 X 4	404-1	404-2	404-3		404-4		404-5	404-6	404-7
3 X 4	303-1	404-2	404-3		404-4		404-5	404-6	404-7
3 X 3	303-1	303-2	303-3		303-4		303-5	303-6	303-7
2 X 3	202-1	303-2	303-3		303-4		303-5	303-6	303-7
2 X 2	202-1	202-2	303-3		303-4		303-5	303-6	303-7

1641 W Commerce Ct #151
Tucson, AZ 85746

T 520-888-4101
TF 800-666-8320
info@mseinc.net



MILLER

SALES & ENGINEERING INC.

mseinc.net